

Innovative Monitoring Tool for DENR-Penro Albay's Small Water Impounding System (SWIS)

Nikka N. Olaguer
University of Santo Tomas-Legazpi
nikka.olaguer@ust-legazpi.edu.ph

Date Submitted:
February 28, 2026

Date Accepted:
March 30, 2026

Date Published:
April 13, 2026

DOI:
10.5281/zenodo.19555927

ABSTRACT

This study assessed the monitoring guidelines and performance of the Small Water Impounding System (SWIS) implemented under the Department of Environment and Natural Resources – Provincial Environment and Natural Resources Office (DENR-PENRO Albay). Specifically, the study aimed to describe the existing monitoring practices in terms of system maintenance, water distribution, and resource utilization; determine performance gaps based on the perspectives of farmer-beneficiaries and technical personnel; and develop enhanced monitoring guidelines to improve implementation and ensure the long-term sustainability of SWIS operations. The study also examined institutional and operational factors affecting

monitoring effectiveness in support of agricultural productivity, reforestation activities, and climate resilience. A descriptive research design using both quantitative and qualitative approaches was employed. Data were collected through structured questionnaires and open-ended responses from 20 farmer-beneficiaries and 10 DENR-PENRO Albay technical personnel. Weighted mean analysis and qualitative interpretation were used to evaluate monitoring practices, operational performance, and implementation constraints. Results showed that farmer-beneficiaries generally perceived SWIS operations as effective, particularly in improving water availability, supporting crop production, and enhancing livelihoods. However, technical personnel identified several operational constraints, including sedimentation, irregular preventive maintenance, limited manpower, insufficient funding, and outdated monitoring tools. The findings revealed a gap between perceived performance and actual operational conditions, indicating that positive user satisfaction does not always reflect the true status of system functionality. The study concluded that although SWIS significantly supports agricultural and environmental programs, the existing monitoring framework needs improvement to ensure sustainable and climate-resilient water resource management. The adoption of the enhanced participatory monitoring guidelines and the proposed monitoring dashboard is recommended to strengthen monitoring efficiency, improve coordination, and support long-term sustainability of SWIS implementation in Albay.

Keywords: *Small Water Impounding Systems (SWIS), Monitoring Guidelines; DENR-PENRO Albay; Water Resource Management, Continuous Improvement*

INTRODUCTION

Natural resources remain at the core of community survival and economic stability, particularly in areas where agriculture serves as the primary source of livelihood. Globally, pressures brought about by population growth, climate change, and increasing demand for productive land have elevated water management into a critical sustainability issue. Efficient infrastructure and effective governance in water

systems are considered essential strategies to address water stress and promote resilience in vulnerable communities. In the Philippines, agricultural productivity and rural livelihoods depend heavily on stable water access, yet many regions experience seasonal shortages, erratic rainfall patterns, and unequal distribution of water resources. These realities underscore the importance of government interventions that safeguard water availability, improve agricultural productivity, and strengthen community resilience.

To address concerns on resource sustainability, the Department of Environment and Natural Resources (DENR) was reorganized under Executive Order No. 192, series of 1987, to serve as the primary government agency responsible for conserving, managing, and developing the country’s environment and natural resources. The Department envisions the Philippines as “a nation enjoying and sustaining its natural resources and a healthy environment.” This vision guides the implementation of programs that promote environmental protection while supporting social and economic development. At the provincial level, these mandates are carried out by the Provincial Environment and Natural Resources Office (PENRO), which ensures the effective implementation of DENR policies and environmental programs, including initiatives related to water resource development and watershed management.

One of the key infrastructure initiatives implemented by the DENR is the establishment of Small Water Impounding Systems (SWIS). These are engineered; box-type water storage structures constructed across narrow valleys or depressions to collect and store rainfall and surface runoff during the wet season. The stored water provides multiple benefits, including irrigation for agricultural lands, improved seedling survival in reforestation sites, groundwater recharge, and reduced vulnerability to drought and soil erosion. By ensuring the availability of water even during dry periods, SWIS contributes significantly to food security, watershed protection, and climate resilience in rural communities.

The design and structural components of a typical Small Water Impounding System include a spring box, storage tank, pipelines, inlet and outlet valves, and overflow structures that regulate the storage and distribution of water. These components are carefully designed to ensure efficient water collection, safe storage, and controlled distribution to designated service areas.

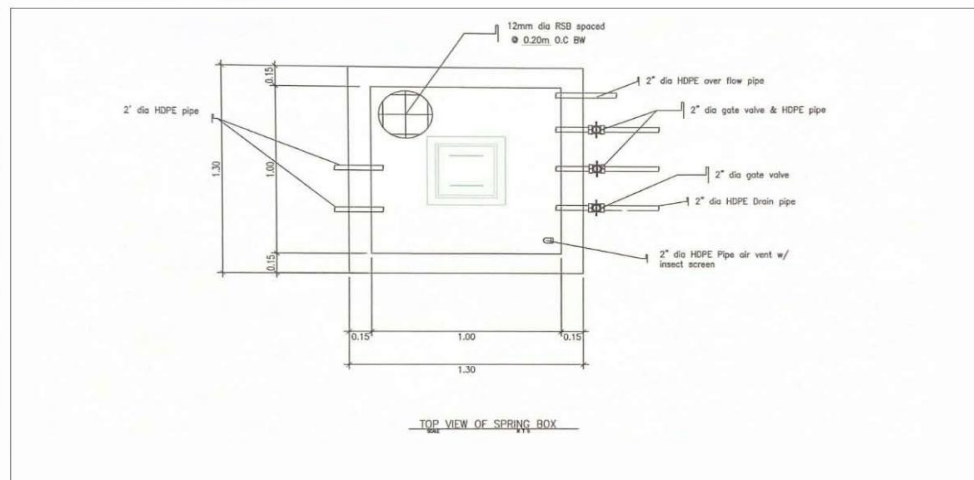

Figure 1. Top View and Side View of the Spring Box Structure of a Small Water Impounding System (SWIS).

Figure 1 illustrates the structural design of the spring box, which serves as the primary intake component of the SWIS. Water from the source is collected through inlet pipes and conveyed into the storage system. The design includes air vents, overflow pipes, and drainage outlets that help regulate water flow, prevent pressure buildup, and maintain the structural safety of the system

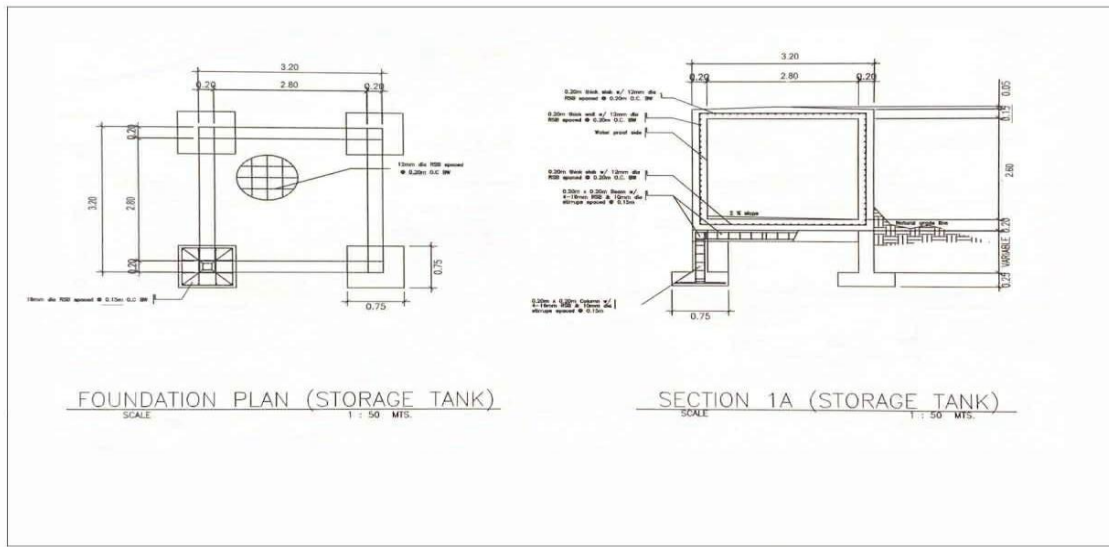

Figure 2. *Ground Level Plan and Front Elevation of the SWIS Storage Tank*

Figure 2 presents the ground level plan and front elevation of the storage tank, which functions as the main reservoir of the system. The storage tank temporarily holds the collected water before it is distributed to service areas. Reinforced concrete construction and properly designed inlet and outlet connections ensure structural stability and adequate storage capacity

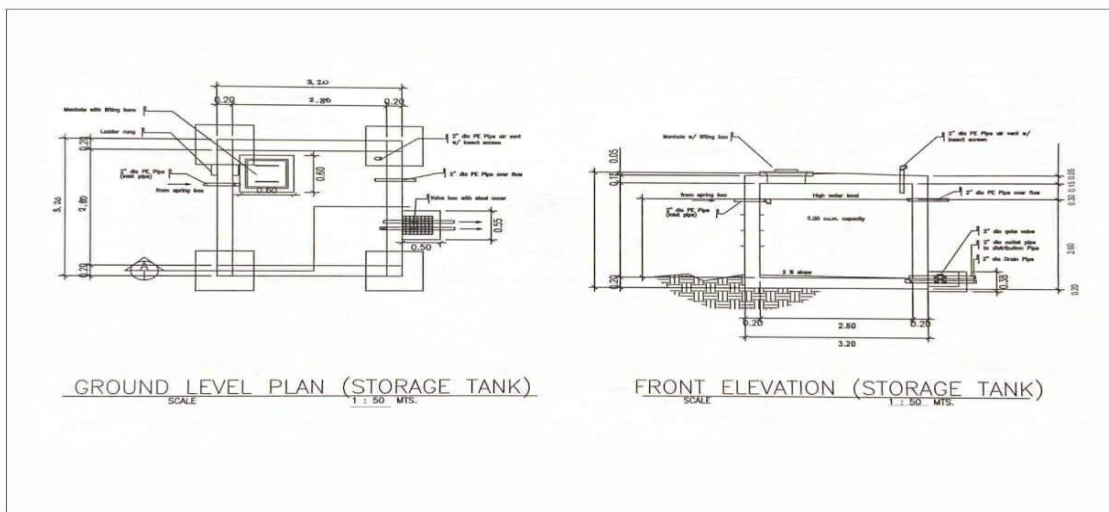

Figure 3. *Foundation Plan and Section View of the SWIS Storage Tank*

Site selection for SWIS is based on several hydrological and environmental factors such as catchment size, rainfall flow patterns, water retention capacity, and accessibility of the area. In addition, the location of National Greening Program (NGP) sites is also considered during the selection process, since SWIS is designed to support the water requirements of reforestation areas established under the program. By strategically locating the system near NGP plantation sites, the stored water can be utilized to sustain the growth and survival of newly planted seedlings, particularly during dry periods when natural water sources are limited. PENRO engineers and technical staff conduct surveying, topographic mapping,

and engineering design prior to construction. The design process includes the development of spillways, intake and outlet structures, storage tanks, and pipelines intended to distribute water to service areas. Before construction begins, DENR secures the necessary environmental permits, such as the Environmental Compliance Certificate (ECC), to ensure compliance with environmental regulations and to minimize ecological disruption.

In Albay Province, the DENR-PENRO has implemented SWIS projects under the 2018 Central Office-Based Funds, which were allocated to enhance water resource management across the country. The construction of each project undergoes a government-regulated bidding process in accordance with Republic Act 4566 (Contractor's License Law) and Republic Act 9184 (Government Procurement Reform Act). Contractors must obtain proper accreditation from the Philippine Contractors Accreditation Board (PCAB) and demonstrate experience in similar projects within the last ten years. Payments to contractors are based on actual accomplishments validated through progress billing by the Project Inspection Committee composed of BAC members, COA personnel, and financial analysts. Meanwhile, DENR-PENRO Albay technical personnel conduct annual site inspections during the third quarter of each year to ensure compliance with contract specifications and to assess the operational functionality of the systems.

These systems also support the National Greening Program (NGP) of the Department of Environment and Natural Resources. The NGP is a nationwide reforestation and ecological restoration initiative aimed at rehabilitating degraded forestlands, enhancing biodiversity, and mitigating the impacts of climate change. In Albay, the water stored in Small Water Impounding Systems directly contributes to the NGP by sustaining newly planted seedlings in reforestation areas, thereby improving survival rates and supporting the long-term success of the program.

In addition to supporting reforestation efforts, SWIS also provides a sustainable water source for nearby farmlands. The stored water is used for irrigation, enabling farmers to cultivate crops even during dry periods. As the primary beneficiaries, farmers directly benefit from the consistent water supply, which helps stabilize crop yields and reduce the impacts of drought. This dual function strengthens agricultural productivity, supports rural livelihoods, and promotes sustainable natural resource management within the province.

At present, fifteen SWIS units are operational in Albay. Fourteen of these are located in the province's third district, specifically in Badian (Oas), Basicao (Pioduran), Bogtong (Oas), Maonon (Ligao City), Maramba (Oas), Oma-Oma (Ligao City), Pantao (Libon), Ponso (Polangui), Ponso (Oas), Quinali River (Guinobatan), Sugcad (Polangui), and Talin-Talin (Libon). One unit is located in the second district in Cabrarán (Camalig), while another is located in the first district in Namantao (Bacacay). Each unit is constructed based on approved plans and specifications, with an average project duration of approximately four months and a total storage capacity of about 37.49 cubic meters.

Despite their importance, the operation of SWIS in Albay continues to face several challenges. Issues related to system maintenance, water distribution, and resource utilization reduce efficiency and limit the systems' ability to fully achieve their intended outcomes. Furthermore, the absence of standardized monitoring guidelines and performance evaluation mechanisms prevents DENR-PENRO Albay from systematically identifying operational gaps and implementing timely improvements.

In response to these concerns, this study sought to describe the monitoring guidelines of SWIS in Albay under the management of DENR-PENRO, focusing on system maintenance, water distribution, and resource utilization; to determine the performance gaps in the implementation of SWIS; and to propose guidelines for performance monitoring and continuous improvement. By addressing these objectives, the study aimed to strengthen the reliability and effectiveness of SWIS as an essential water infrastructure that supports agriculture, reforestation, and community resilience in Albay.

Water resource management plays a key role in sustaining agriculture, protecting the environment, and supporting rural communities. The Small Water Impounding System (SWIS) serves as one of the major interventions to ensure a steady water supply in rain-dependent and drought-prone areas. The DENR-PENRO Albay has implemented several SWIS units that contribute to irrigation, watershed conservation, and the National Greening Program (NGP), benefiting both farmers and the environment.

The National Greening Program (NGP), implemented by the Department of Environment and Natural Resources (DENR) through Executive Order No. 26, s. 2011, is a nationwide initiative aimed at addressing climate change, promoting the sustainable management of natural resources, and reducing poverty through forest restoration and sustainable land management practices. The program targets the establishment of approximately 1.5 billion trees across about 1.5 million hectares of land throughout the country. In the Province of Albay, DENR has developed approximately 16,877.29 hectares of NGP plantation areas from 2012 to 2024. The sustainability of these plantation areas relies significantly on the availability of water resources, particularly in locations vulnerable to seasonal drought.

In support of these initiatives, Small Water Impounding Systems (SWIS) function as a complementary mechanism for NGP implementation by providing water sources that help sustain reforestation sites and maintain watershed functions. At the same time, these systems support the irrigation needs of nearby agricultural lands, benefiting farmer-beneficiaries located within the vicinity of SWIS sites. Through this dual function, SWIS contributes both to environmental restoration efforts under the NGP and to the improvement of agricultural productivity in local communities.

This study sought to refine the monitoring guidelines for the SWIS projects managed by DENR-PENRO Albay. The refinement of the framework aims to improve consistency with standards, elevate operational performance, and reinforce accountability. Ultimately, it sought to ensure the long-term sustainability and reliability of SWIS operations for agricultural and environmental development in Albay.

Literature on Small Water Impounding Systems (SWIS) in the Philippines has largely concentrated on their engineering design, technical standards, and role in watershed management. The Bureau of Soils and Water Management (BSWM) leads the national SWIS program, focusing on watershed rehabilitation, soil erosion control, and sustained water supply for agricultural areas. The Philippine Agricultural Engineering Standard (PAES) establishes the minimum technical specifications for SWIS, including embankment design, spillway construction, and irrigation components (Philippine Agricultural Engineering Standard). Complementing this, the Philippine National Standard provides detailed guidance on site selection, hydrological evaluation, and dam safety requirements. The Forest Management Bureau (FMB), through its Technical Bulletin No. 15, further outlines cost estimates, site assessment procedures, and operational guidelines for small impounding projects. Collectively, these technical and policy documents establish the institutional foundation for SWIS implementation and maintenance across the country.

Despite the presence of these comprehensive technical frameworks, limited scholarly attention has been devoted to the systematic monitoring and performance evaluation of SWIS at the local level. Most studies emphasized structural integrity and efficiency, yet few examine governance mechanisms or institutional monitoring practices that ensure long-term functionality and sustainability. Additionally, research often overlooks socio-environmental factors, such as equitable water distribution and the contribution of SWIS to reforestation efforts under the National Greening Program (NGP).

These gaps highlighted the need for a more structured and performance-based monitoring framework that aligns engineering standards with on-ground operational realities. This study responded to that need by refining the monitoring guidelines for DENR-PENRO Albay, thereby strengthening performance evaluation, promoting accountability, and ensuring the long-term sustainability of SWIS operations in support of agricultural productivity and environmental conservation in the province.

LITERATURE REVIEW

Innovative Monitoring Tools

Innovation in monitoring systems has become an important approach in improving the efficiency, accuracy, and reliability of project supervision, particularly in government-implemented environmental and water resource programs. Traditional monitoring methods that rely on manual recording, paper-based reports, and delayed submission of data often result in incomplete information and difficulty in evaluating project performance. Because of these limitations, organizations have started adopting innovative monitoring tools that utilize digital technologies, integrated databases, and automated reporting systems to strengthen monitoring and evaluation processes. These modern monitoring approaches allow implementing agencies to collect, store, and analyze data more efficiently, thereby improving decision-making and overall project management (Adam, 2025).

Innovative monitoring tools are commonly developed using computerized and web-based systems that provide centralized storage of monitoring data from different project sites. Through the use of digital monitoring platforms, project information can be accessed easily by administrators, allowing them to evaluate operational indicators and identify performance gaps in a timely manner. Studies on web-based monitoring and evaluation systems show that digital platforms reduce the time required for data processing and reporting while improving the consistency and accuracy of project records (Mtebe & Raisamo, 2020). These systems are especially useful in government programs where multiple projects must be supervised simultaneously, requiring organized and reliable information for effective management.

Monitoring innovation is also closely associated with the development of decision-support systems that assist managers in evaluating project performance using structured and analyzable data. Decision-support systems integrate data collection, processing, and visualization functions that help administrators compare actual performance with expected targets. According to Power (2002), decision-support systems improve organizational monitoring by providing timely and relevant information needed for planning, control, and corrective action. In infrastructure-related projects, these systems are valuable because they allow managers to monitor several operational components at the same time, ensuring that problems are detected early and addressed before they affect the overall performance of the project.

Another important development in innovative monitoring is the use of dashboard-based monitoring platforms. Dashboards present monitoring indicators in graphical and summarized form, making it easier for users to understand project conditions without reviewing lengthy reports. Few (2013) explained that dashboards enhance monitoring efficiency by transforming complex data into visual information that can be interpreted quickly by decision-makers. In government and environmental programs, dashboard-type monitoring systems support better coordination between field personnel and supervising offices because monitoring results can be viewed in real time. This allows administrators to respond immediately to operational issues and to ensure that project activities are carried out according to planned objectives.

In the field of water resource management, innovative monitoring tools have been widely recommended to ensure the sustainability of irrigation systems, reservoirs, and small water impounding facilities. The Food and Agriculture Organization (FAO, 2017) emphasized that structured monitoring supported by digital recording systems improves the ability of implementing agencies to track infrastructure condition, water availability, and utilization efficiency. Reliable monitoring information is necessary for planning maintenance activities, allocating resources, and preventing system failure. Continuous and organized monitoring is particularly important in small water impounding systems, where proper operation directly affects agricultural productivity and community water supply.

The integration of information and communication technology (ICT) in monitoring has further strengthened the capability of institutions to supervise projects located in different areas. ICT-based monitoring systems allow field personnel to submit reports electronically, which are automatically stored in a centralized database for evaluation and documentation. According to Kusek and Rist (2004), results-

based monitoring systems supported by digital tools improve program management by ensuring that performance data are regularly collected, analyzed, and used in decision-making. These systems also promote transparency and accountability because monitoring results can be easily reviewed by supervisors, managers, and other stakeholders involved in the project.

In the Philippines, the use of innovative monitoring systems has been gradually adopted in government environmental and water resource programs to improve project supervision and reporting efficiency. Various national agencies have introduced digital monitoring and evaluation tools to strengthen the implementation of development projects, particularly those involving natural resource management, irrigation, and reforestation. The Department of Environment and Natural Resources (DENR) has implemented monitoring mechanisms in programs such as the National Greening Program (NGP), where monitoring reports, geo-tagging, and database recording are used to track project accomplishments and site conditions. These monitoring practices help ensure that project activities are properly documented and that implementing units comply with established guidelines (DENR, 2016).

Similarly, water resource and irrigation-related projects in the Philippines require systematic monitoring to ensure that facilities remain functional and beneficial to farmer-beneficiaries. The National Irrigation Administration (NIA) emphasizes the importance of regular monitoring and reporting in maintaining irrigation structures and water impounding facilities, as proper supervision helps prevent structural damage, inefficient water distribution, and poor resource utilization (NIA, 2018). Monitoring systems supported by organized records and updated reports allow implementing agencies to evaluate project performance and to identify areas that need immediate attention.

Local studies on monitoring and evaluation of government projects also highlight the need for improved monitoring tools that can provide faster and more accurate information. Manual monitoring procedures are often associated with delays in reporting and difficulty in retrieving past records, which may affect the quality of project supervision. Researchers have recommended the development of computerized monitoring systems and dashboard-based tools to make monitoring more systematic, accessible, and reliable, especially for projects implemented in multiple locations (Reyes, 2020). The use of innovative monitoring tools therefore supports better coordination between field personnel and supervising offices and helps ensure that project objectives are achieved.

In relation to the Small Water Impounding System (SWIS), the development of an innovative monitoring tool can help strengthen the monitoring procedures of DENR-PENRO Albay by providing a more organized and efficient method of recording, storing, and evaluating project data. By integrating digital monitoring, standardized indicators, and centralized data management, an innovative monitoring system can address the limitations of conventional monitoring practices and enhance the overall supervision of SWIS projects. This supports the need to develop an innovative monitoring tool that will assist DENR-PENRO Albay in effectively monitoring the operational performance and implementation status of Small Water Impounding Systems.

System Maintenance

System maintenance is a fundamental operational practice that directly influences the functionality, safety, and longevity of Small Water Impounding Systems. Regular inspection, desilting, and repair activities are essential to prevent structural deterioration and ensure continuous water availability for agricultural use (Bruns & Meinzen-Dick, 2018). Maintenance practices that focus on early identification of defects reduce the likelihood of major system failures and help sustain the intended benefits of water infrastructure projects.

Preventive maintenance has been widely recognized as a cost-effective approach in managing water infrastructure. By addressing minor issues before they escalate into major problems, preventive maintenance reduces long-term repair costs and minimizes system downtime (Harvey & Reed, 2007). In

small-scale water systems, routine embankment inspection, vegetation control, and outlet maintenance contribute significantly to operational sustainability and reliability.

The effectiveness of system maintenance is closely linked to institutional arrangements and role clarity. Clearly defined responsibilities between implementing agencies and beneficiaries improve coordination and ensure that maintenance tasks are carried out in a timely manner (ADB, 2016). Conversely, unclear maintenance roles often result in delayed interventions and gradual system degradation, affecting overall performance. Community participation further strengthens system maintenance practices. Involving local users in basic maintenance activities fosters a sense of ownership and shared responsibility, which enhances compliance with maintenance schedules and reduces dependence on government intervention (Pretty, 2011). Community-supported maintenance contributes to improved system condition and long-term sustainability.

Maintenance performance is also shaped by institutional capacity and resource availability. Adequate technical skills, manpower, and access to appropriate tools enable maintenance personnel to respond effectively to emerging issues (UNDP, 2016). In contrast, limited capacity leads to irregular inspections, deferred maintenance, and incomplete documentation, weakening system reliability.

Climate-related risks have further emphasized the importance of adaptive maintenance strategies. Extreme weather events increase the likelihood of siltation, erosion, and structural damage in water impounding systems, necessitating maintenance plans that incorporate emergency preparedness and climate resilience measures (IPCC, 2021).

System maintenance challenges in small-scale water infrastructure projects are frequently associated with limited funding, insufficient technical expertise, and weak coordination among stakeholders. Maintenance delays and inadequate planning have been linked to declining system performance and reduced water storage capacity (David, 2011). Strengthening maintenance planning and monitoring is therefore critical to sustaining system functionality.

Scheduled maintenance programs have been associated with better structural integrity and operational outcomes in Philippine small water impounding systems. Regular desilting, inspection, and repair activities contribute to improved water retention and system efficiency (Garcia & Garcia, 2019). Community involvement in maintenance activities has also been shown to reduce maintenance backlogs and improve system reliability (Reyes et al., 2021). Capacity-building initiatives that equip local stakeholders with basic maintenance skills further enhance system sustainability (DA-BSWM, 2018).

Water Distribution

Water distribution is a central operational function of Small Water Impounding Systems, as it determines how stored water is allocated among beneficiaries and directly affects agricultural productivity. Effective water distribution practices ensure that water is delivered in a timely, adequate, and equitable manner, thereby maximizing system benefits (Bruns & Meinzen-Dick, 2018). Clear allocation rules and delivery schedules reduce conflicts and promote efficient system use.

Efficiency in water distribution has been strongly associated with improved agricultural outcomes and reduced water losses. Well-managed distribution systems optimize water use and ensure that available resources are matched with crop water requirements (FAO, 2017). In contrast, inefficient scheduling and poor control mechanisms often result in water wastage and unequal access among users.

Equity is a recurring concern in shared water systems. Unequal access to water undermines collective management and weakens stakeholder cooperation. Transparent distribution rules and enforcement mechanisms support fairness and strengthen trust among beneficiaries (Meinzen-Dick & Zwarteveen, 2001). Governance structures that define authority and responsibility play a key role in maintaining equitable distribution practices (ADB, 2016).

Monitoring of water flow and usage further enhances distribution performance. Measuring discharge rates and tracking usage patterns enable managers to detect inefficiencies, unauthorized use, and infrastructure-related losses (World Bank, 2020). Regular monitoring supports data-driven adjustments to distribution schedules, particularly during periods of water scarcity. Infrastructure condition significantly affects water distribution efficiency. Deteriorated canals, gates, and control structures contribute to leakage and uneven water delivery, reducing system effectiveness (Harvey & Reed, 2007). Timely maintenance of distribution components is therefore essential to ensure reliable water supply.

Water distribution challenges are often linked to weak institutional enforcement and limited monitoring. In communal irrigation and small water impounding systems, the absence of clear allocation rules has been associated with conflicts and inequitable access, particularly during dry seasons (David, 2011; Panella, 2016). Strengthening distribution guidelines and stakeholder participation has been identified as a key strategy for improving equity and efficiency.

Studies conducted in Luzon indicated that infrastructure condition and management practices significantly influence water delivery performance. Poorly maintained canals and gates disproportionately affect downstream users, highlighting the need for coordinated maintenance and distribution planning (Garcia & Garcia, 2019). Farmer participation in distribution planning has also been associated with improved compliance with water schedules and reduced disputes (Reyes et al., 2021). National agencies have emphasized the importance of adaptive distribution planning to address seasonal water scarcity and climate variability (DA-BSWM, 2018; DENR-FMB, 2020).

Resource Utilization

Resource utilization refers to the effective use of financial, human, and material resources to support the operation and sustainability of Small Water Impounding Systems. Efficient resource utilization ensures that organizational inputs are converted into desired outputs with minimal waste, contributing to improved system performance and service delivery (Armstrong, 2009). In public sector programs, optimal resource use is essential for achieving operational efficiency under resource-constrained conditions.

Financial resource utilization plays a critical role in sustaining system operations. Timely allocation and efficient use of funds support routine maintenance, monitoring, and repair activities, while delays in fund release often result in postponed interventions and declining system performance (World Bank, 2020). Effective financial planning and budgeting are therefore essential components of operational sustainability.

Human resource utilization is equally important in water system management. Skilled technical staff and field personnel are responsible for inspection, monitoring, maintenance, and reporting activities. Efficient deployment of human resources enhances responsiveness to operational issues and improves overall system reliability (UNDP, 2016). Conversely, understaffing and limited technical expertise contribute to monitoring gaps and delayed maintenance. Material and equipment utilization further influences operational effectiveness. Proper use and maintenance of tools and equipment support efficient system operations and reduce operational costs (Harvey & Reed, 2007). Weak inventory management and inadequate equipment availability often result in increased downtime and reduced system efficiency.

Community contributions are increasingly recognized as valuable supplemental resources in small-scale water systems. Local labor, materials, and indigenous knowledge enhance resource efficiency and reduce dependence on external funding (Pretty, 2011). Community-based approaches to resource utilization strengthen collective responsibility and support long-term sustainability.

In the Philippine setting, challenges in resource utilization are commonly associated with delayed budget releases, limited technical manpower, and weak coordination among implementing agencies. These constraints affect the timely implementation of maintenance and operational activities in water infrastructure projects (Briones, 2017; David, 2011). Improving coordination and clarifying resource allocation responsibilities have been identified as key strategies for enhancing efficiency.

Studies on Philippine small water impounding systems highlighted the importance of coordinated resource management among government agencies, field offices, and beneficiaries. Efficient use of materials and equipment has been linked to improved system reliability and reduced breakdowns (Garcia & Garcia, 2019). Farmer participation in resource-related decision-making has also been shown to enhance efficiency and align resource use with actual operational needs (DA-BSWM, 2018; Reyes et al., 2021). Clear guidelines on resource allocation and utilization further improve transparency and accountability in system operations (DENR-FMB, 2019).

Synthesis of the Art

The reviewed literature and previous studies provided important concepts and perspectives that guided the development of this research. These sources served as references in identifying appropriate approaches for strengthening the monitoring system of Small Water Impounding Systems (SWIS), particularly in relation to maintenance, water distribution, resource utilization, and monitoring effectiveness. Monitoring guidelines and performance evaluation frameworks are essential in ensuring that water resource projects are properly implemented, maintained, and sustained over time (Department of Environment and Natural Resources [DENR], 2016; National Irrigation Administration [NIA], 2018).

The establishment of Small Water Impounding Systems has been recognized as an important support mechanism for irrigation, watershed rehabilitation, and reforestation activities under government environmental programs. In the Philippines, SWIS projects are implemented to provide reliable water supply for agricultural production while also supporting forest restoration and climate resilience initiatives under the National Greening Program (DENR, 2019). In the province of Albay, several SWIS units are under the supervision of DENR-PENRO and serve as support facilities for irrigation, forest plantation maintenance, and livelihood improvement among farmer-beneficiaries. However, reports from monitoring activities indicate that the effectiveness of these projects is influenced by the consistency of maintenance, availability of resources, and the quality of monitoring procedures (Reyes, 2020).

Existing literature also emphasized that the success of irrigation and water impounding projects depends not only on the construction of facilities but also on proper monitoring, documentation, and coordination among implementing agencies and beneficiaries. Monitoring systems that lack clear performance indicators, standardized reporting, and regular evaluation may result in incomplete assessment of project conditions, making it difficult to identify operational problems at an early stage (DENR, 2016). In government infrastructure and environmental projects, inconsistent data collection and limited field supervision often lead to gaps between policy guidelines and actual implementation (NIA, 2018; Reyes, 2020).

These gaps highlighted the need for clearer monitoring standards, improved data management, and stronger coordination between technical personnel and beneficiaries. Effective monitoring frameworks should include defined indicators, regular inspection schedules, and organized reporting systems to ensure that project performance can be accurately evaluated and improved. Strengthening monitoring procedures is particularly important in water resource projects, where system failure may directly affect agricultural productivity, environmental rehabilitation, and community livelihood.

In response to these identified concerns, the present study focused on developing enhanced monitoring guidelines for SWIS sites in Albay. The study aims to improve monitoring efficiency, strengthen accountability, and support sustainable water resource management by proposing a more systematic and participatory monitoring approach that is responsive to the operational conditions of SWIS implementation.

Problem in the Field

Despite the significant potential of Small Water Impounding Systems (SWIS) in enhancing water availability and agricultural productivity, several operational challenges continue to limit their efficiency and long-term sustainability. Small water impounding projects in the Philippines are designed to store rainfall and runoff for irrigation, watershed management, and livelihood support; however, their effectiveness depends largely on proper operation, maintenance, and monitoring after construction (Bureau of Soils and Water Management, 2017; NIA, 2018). When monitoring is not consistently implemented, irrigation facilities may gradually deteriorate, resulting in reduced water supply and lower agricultural productivity.

Operational constraints such as poor maintenance, unequal water distribution, and limited monitoring practices continue to affect the performance of water impounding systems. A study on small water impounding projects in Quirino Province reported that although SWIP improved crop yield and farmer income, the sustainability of the system depended on regular maintenance, proper monitoring, and active participation of beneficiaries (Naval, 2016). Similar findings were observed in irrigation performance studies in the Cagayan River Basin, where degradation of irrigation facilities and inefficient use of resources were linked to inadequate supervision and lack of systematic performance evaluation (Bareng, 2015). These conditions highlight the importance of strengthening monitoring systems to ensure that irrigation facilities remain functional over time.

In the Philippines, small-scale irrigation and water impounding projects are often managed by different agencies, and weak institutional coordination may affect project monitoring and implementation. Rola (2019) noted that unclear institutional linkages and limited coordination among agencies involved in irrigation and watershed management can result in gaps in monitoring, reporting, and maintenance activities. When monitoring responsibilities are not clearly defined, evaluation of project performance becomes inconsistent, making it difficult to identify operational problems at an early stage.

Another concern is the absence of standardized monitoring guidelines for ongoing SWIS operations. Existing guidelines often focus on planning and construction, while operational monitoring receives less attention. National standards for Small Water Impounding Systems emphasize the need for regular inspection, documentation, and performance evaluation to ensure that reservoirs, canals, and control structures remain efficient and safe (AMTEC, 2017). Without continuous monitoring, problems such as sedimentation, leakage, and underutilized storage capacity may not be immediately detected, which can reduce the effectiveness of the system.

Limited scholarly attention has also been given to monitoring frameworks specifically designed for Small Water Impounding Systems at the local level. While several studies discuss irrigation management in general, fewer studies focus on the evaluation of monitoring practices in SWIS projects implemented under environmental and watershed programs. Since these systems support both agricultural production and reforestation activities, continuous monitoring is necessary to ensure that both livelihood and environmental objectives are achieved (BSWM, 2017).

For farmers as primary beneficiaries, these deficiencies may result in unreliable irrigation supply, delayed water release, and reduced crop productivity, especially during dry periods. Previous studies on irrigation systems in the Philippines show that inconsistent water distribution and lack of coordination between implementing agencies and beneficiaries can reduce system efficiency and weaken community participation (NIA, 2018).

For DENR-PENRO Albay, the absence of a standardized monitoring framework limits the ability to ensure operational sustainability, institutional accountability, and alignment with agricultural and environmental goals. Government project monitoring guidelines emphasize that continuous evaluation, proper documentation, and coordinated implementation are necessary to maintain project performance and ensure efficient use of public resources (DENR, 2016). Without a systematic mechanism for monitoring and performance evaluation, the long-term

sustainability of SWIS remains uncertain.

These conditions indicate the need to develop improved monitoring guidelines and more systematic performance evaluation procedures to strengthen the implementation of Small Water Impounding Systems and support sustainable water resource management at the provincial level.

Research Gap

Studies have already been conducted on sustainable water resource management and the implementation of Small Water Impounding Systems (SWIS). Likewise, research on water conservation and irrigation development has been increasing, particularly in the fields of agriculture, watershed rehabilitation, and environmental management. Several studies have also discussed the technical and operational aspects of SWIS implementation. However, there is yet no existing study on the monitoring guidelines of DENR-PENRO Albay for the management and operation of SWIS in the province. Specifically, there has been no assessment of the monitoring mechanisms, maintenance practices, and performance evaluation systems employed in these projects. These are the gaps that the present study seeks to address.

Objectives of the Study

This study assessed the monitoring practices and operational performance of the Small Water Impounding System (SWIS) in Albay to provide a basis for improving performance evaluation. Specifically, it sought to:

1. Describe the operational practices of SWIS in Albay in terms of:
 - a. system maintenance;
 - b. water distribution; and
 - c. resource utilization.
2. Determine the performance gaps in the implementation of SWIS; and
3. Design a dashboard as a monitoring tool for the Small Water Impounding System (SWIS).

Theoretical Framework

This study is anchored on three interrelated theories: Systems Theory (Bertalanffy, 1950), Performance Management Theory (Armstrong, 2009), and the Kaizen Theory of Continuous Improvement (Imai, 1986). These theories provide a comprehensive basis for understanding, evaluating, and improving the operations of DENR-PENRO Albay's Small Water Impounding Systems (SWIS).

Systems Theory views SWIS as an integrated system composed of structural, human, and environmental components. Inefficiencies in any component such as maintenance, resource management, or environmental management can destabilize overall system performance. This theory underscores the importance of viewing SWIS as a cohesive whole, where the interdependence of all components determines operational effectiveness.

Performance Management Theory emphasizes measurable indicators, systematic evaluation, and feedback mechanisms to achieve efficiency and accountability. In the context of SWIS, this theory supports the assessment of operational performance using indicators such as water storage levels, pump efficiency, filtration performance, and maintenance compliance. Regular monitoring and feedback allow for data-driven decisions to enhance system operations and service delivery.

Kaizen Theory of Continuous Improvement advocates for small, incremental improvements guided by collective participation and data-driven decision-making. For SWIS, the Kaizen approach promotes continuous evaluation of operational processes, identification of inefficiencies, and implementation of minor changes that cumulatively improve water management, reduce resource wastage, and ensure sustainability.

In this study, the researcher measures the performance of SWIS operations in Albay using the principles of these three theories. The framework considers system integrity, resource management, operational efficiency, and maintenance practices as key factors. It examines how these factors interact to affect overall system performance, including water availability, reliability, and sustainability of SWIS operations.

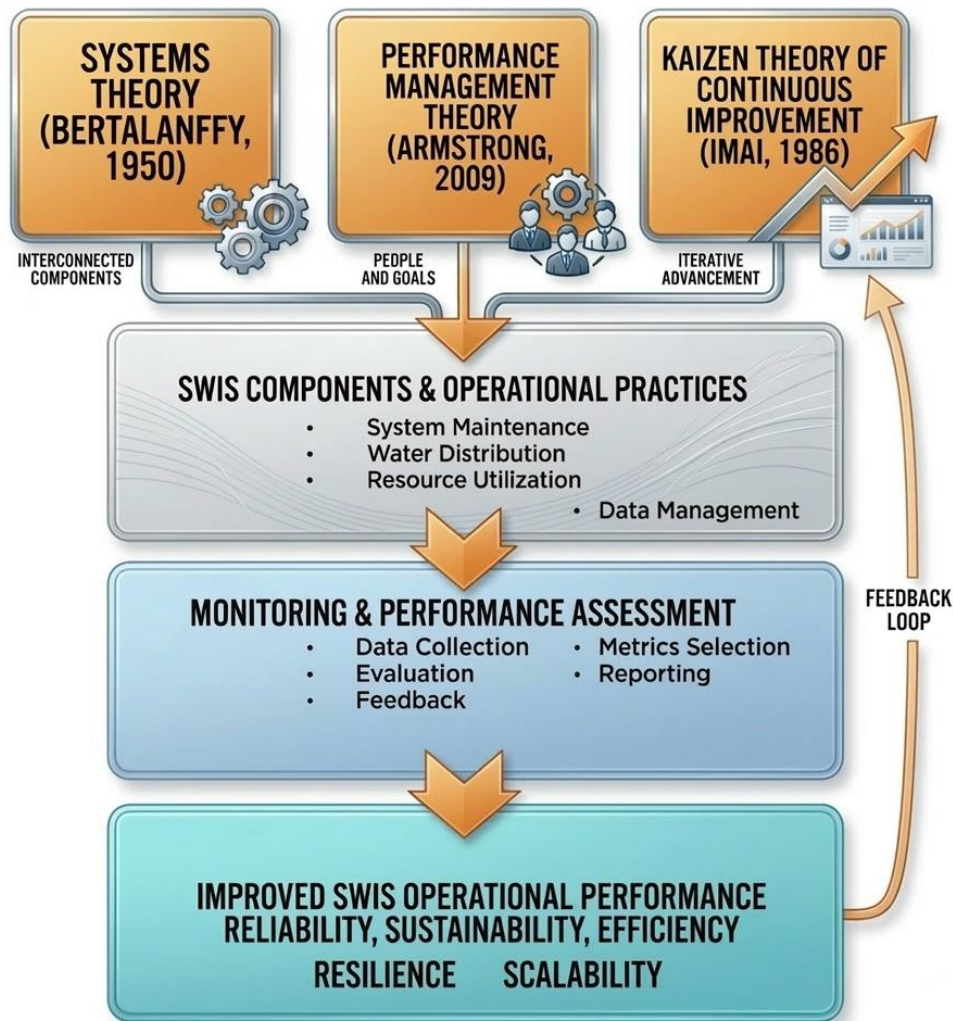

Figure 4. *Theoretical Paradigm Model*

Conceptual Framework

The conceptual paradigm of the study is presented in Figure 2, which follows a systematic process consisting of assessment, identification of performance gaps, formulation of monitoring guidelines, and dashboard-based monitoring for the Small Water Impounding System (SWIS) implemented by DENR-PENRO Albay. The framework shows how the evaluation of operational practices leads to the identification of gaps and the development of guidelines that are integrated into a dashboard to support continuous performance improvement. The first phase focuses on the operational practices of SWIS, specifically system maintenance, water distribution, and resource utilization. These components represent the essential activities required for the proper functioning of the system. System maintenance refers to the regular

inspection and repair of structures, water distribution involves the efficient and equitable delivery of water to beneficiaries, and resource utilization pertains to the proper use of available materials, equipment, and financial support. These practices are assessed to determine the current condition of SWIS operations in Albay. The second phase involves the identification of performance gaps, including inefficiencies, operational challenges, and shortcomings observed during the assessment. Responses from farmer-beneficiaries and DENR-PENRO Albay technical personnel are analyzed to determine the factors affecting the effectiveness of SWIS implementation. The identified gaps serve as the basis for improvement measures.

The third phase is the formulation of guidelines for performance monitoring and continuous improvement. These guidelines provide a structured and standardized approach for evaluating SWIS operations and supporting decision-making related to maintenance, water management, and resource use. The final component is the development of a dashboard, which serves as a monitoring and evaluation tool for DENR-PENRO Albay. The dashboard integrates the assessment results, identified gaps, and monitoring guidelines into a visual system that allows technical personnel to track performance, monitor compliance, and identify issues requiring action. The dashboard also provides feedback to operational practices, creating a continuous improvement cycle. This framework establishes a systematic process in which the assessment of operational practices leads to gap identification, guideline formulation, and dashboard-based monitoring, providing a structured approach for improving the implementation and performance evaluation of the Small Water Impounding System (SWIS) in Albay.

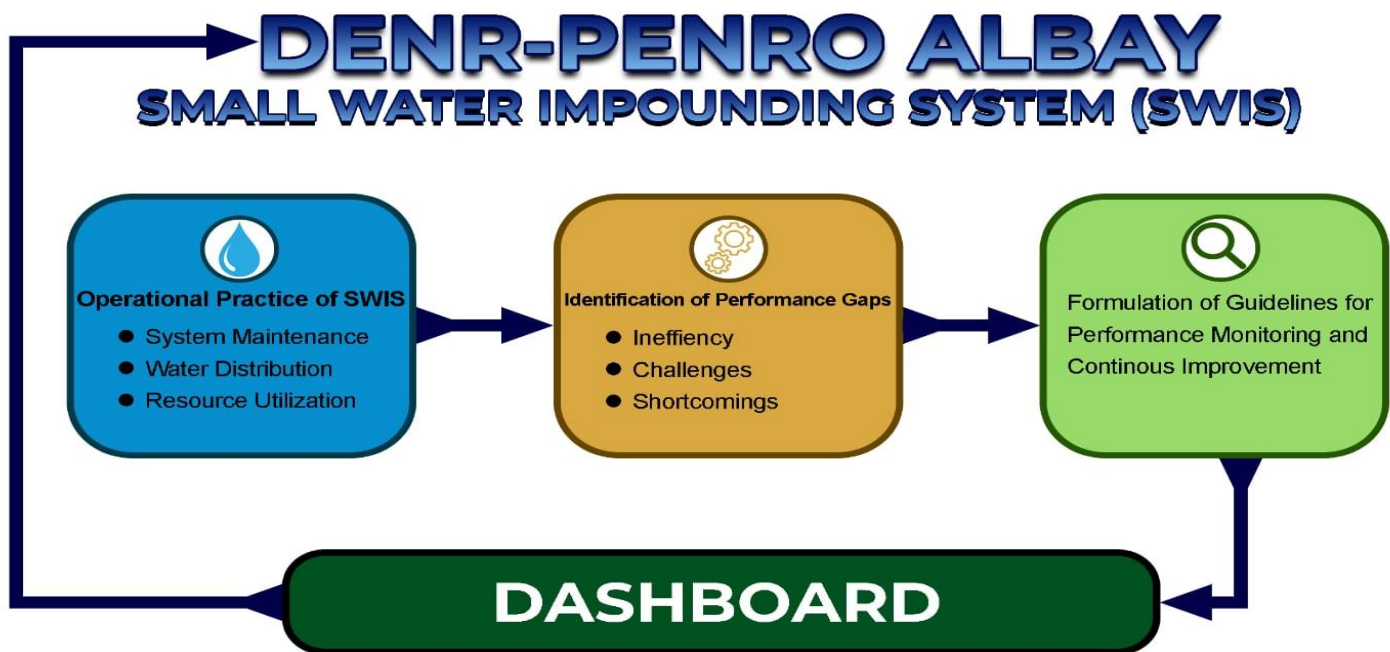

Figure 5. *Conceptual Paradigm of the Study*

Research Design

This study is descriptive research utilizing both quantitative and qualitative data gathered through adopted instruments. This design is commonly used in social and environmental research to describe existing conditions and operational practices without altering any variables. It combines quantitative methods, which focus on measurable data, and qualitative inquiry, which captures the experiences and insights of respondents from DENR-PENRO Albay and farmer-beneficiaries. The design fits this study as it presents the current practices, challenges, and performance gaps in the management of Small Water Impounding Systems (SWIS) through the integration of statistical findings and narrative responses.

Sources of Data

This study utilized both primary and secondary data to examine the implementation and monitoring practices of Small Water Impounding Systems (SWIS) in the Province of Albay. Primary data were collected from two groups of respondents: farmer-beneficiaries and DENR-PENRO Albay technical personnel who are directly involved in the operation, maintenance, and monitoring of SWIS projects. Their responses provided essential information regarding existing operational practices, performance gaps, and management challenges associated with SWIS implementation. A total of 30 respondents participated in the study, consisting of 20 farmer-beneficiaries and 10 DENR-PENRO Albay technical personnel. The farmer-beneficiaries were selected from 8 out of the 15 SWIS sites in Albay, namely: Pantao (Libon) ($n = 2$), Ponso (Polangui) ($n = 3$), Nasisi (Polangui) ($n = 4$), Quinali River (Guinobatan) ($n = 2$), Sugcad (Polangui) ($n = 3$), Cabrarian (Camalig) ($n = 2$), Bogtong (Oas) ($n = 2$), and Namantao (Bacacay) ($n = 2$). These respondents were selected based on their availability during the data gathering period and their direct involvement or familiarity with the operation and utilization of the SWIS facilities in their respective areas. Data were gathered using structured questionnaires employing a Likert scale and open-ended questions, enabling the collection of both quantitative assessments and qualitative insights regarding SWIS operational practices, monitoring activities, and management concerns. Secondary data were obtained from available records, reports, and relevant documents from DENR-PENRO Albay concerning the implementation, operation, and monitoring of SWIS projects within the province. The data covered completed and operational SWIS sites and included verifiable information relevant to the variables examined in the study.

Research Instrument

The study utilized survey questionnaire, which was divided into four parts. The instrument was designed to be answered by the identified respondents of the study, namely the farmer-beneficiaries of the Small Water Impounding System (SWIS) and the DENR-PENRO Albay technical personnel, with specific sections assigned to each group based on the relevance of the information required. Part I covered the respondents' profile, which included basic demographic and work-related information, and this part was answered by both farmer-beneficiaries and DENR-PENRO Albay technical personnel. Part II focused on the operational practices of SWIS, specifically system maintenance, water distribution, and resource utilization, and this part was also answered by both groups to obtain perspectives from implementers and beneficiaries. Part III examined the performance gaps in the implementation of SWIS, particularly in relation to monitoring guidelines, coordination, and data management, and this section was primarily answered by DENR-PENRO Albay technical personnel who are directly involved in the monitoring and implementation of the projects. Part IV consisted of open-ended questions that allowed respondents to elaborate on challenges, benefits, and recommendations, and this part was answered by both farmer-beneficiaries and DENR-PENRO Albay technical personnel to support the interpretation of the results.

Data Gathering Procedure

The researcher sent a formal letter to the DENR-PENRO Albay to request permission to conduct the study. After approval, a meeting was arranged with key DENR-PENRO Technical personnel involved in the operation and monitoring of the Small Water Impounding Systems (SWIS) to discuss the study's objectives, scope, and procedures. The researcher then distributed questionnaires to the identified respondents, composed of DENR-PENRO Technical personnel and farmer-beneficiaries. In addition, relevant documents, reports, and records concerning SWIS implementation and monitoring were reviewed to support the analysis and validation of the gathered data.

Table 1. *Five-Point Likert Scale Used in the Study*

Scale	Interpretation	Abbreviation	Description
5	Strongly Agree	SA	The statement is strong compliance
4	Agree	A	The statement is compliant
3	Moderately Agree	MA	The statement is partially compliant
2	Disagree	D	The statement is minimal compliant
1	Strongly Disagree	SD	The statement is non-compliant

Data Analysis

The responses to the structured questions were measured using a five-point Likert scale. The numerical ratings assigned to each response were used to compute the weighted mean for every indicator and were interpreted descriptively to determine the overall level of implementation and effectiveness of SWIS operational and monitoring practices. The scale used in the study is presented in Table 1.

The computed weighted means were used as the basis for describing the extent of implementation of system maintenance, water distribution, resource utilization, and monitoring practices of the Small Water Impounding System (SWIS).

RESULTS AND DISCUSSIONS

Operational Practices of DENR-PENRO Albay Small Water Impounding System (SWIS) System Maintenance

The system maintenance practices of the Small Water Impounding System (SWIS) were examined based on the perceptions and experiences of the farmer-beneficiaries. From the farmers' perspective, system maintenance is generally viewed as satisfactory and supportive of agricultural activities. Most respondents indicated that key SWIS structures, particularly canals and water conveyance facilities, remain functional and capable of delivering water to their farms, thereby contributing to sustained crop production.

Farmer-beneficiaries acknowledged that maintenance activities such as minor repairs, canal clearing, and water flow monitoring are undertaken through coordination with DENR-PENRO personnel or through community-initiated efforts. Despite these positive observations, concerns were raised regarding the irregularity of scheduled maintenance, particularly in relation to reservoir cleaning and desilting, which are critical for ensuring long-term system efficiency. Table 2 presents the perspectives of the farmer-beneficiaries on the maintenance of the small water impounding system.

Table 2. *Maintenance of the SWIS from the Perspectives of the Farmer Beneficiaries (N=20)*

Indicators	Weighted Mean	Interpretation
<ul style="list-style-type: none"> The SWIS facility is regularly checked and maintained by responsible personnel. 	3.90	Agree

• Dam structures and canals are kept in good working condition	3.85	Agree
• Farmers are informed in advance of any maintenance activities or repairs.	3.70	Agree
• Maintenance problems are reported and resolved promptly.	3.65	Agree
• Farmers are encouraged to participate in maintenance or clean-up activities.	3.90	Agree
Overall Weighted Mean	3.80	Agree

Legend: 1.00–1.49 Strongly Disagree; 1.50–2.49 Disagree; 2.50–3.49 Moderately Agree; 3.50–4.49 Agree; 4.50–5.00 Strongly Agree

The results show an overall weighted mean of 3.80, indicating that farmer-beneficiaries generally agree that system maintenance practices are being implemented. This positive perception is attributed to the continued functionality of canals and water conveyance structures, which effectively deliver water to farm plots, thereby supporting sustained crop production. Maintenance activities, including minor repairs, canal clearing, and water flow monitoring, are carried out through collaborative efforts between DENR-PENRO Albay technical personnel and farmer-beneficiaries, highlighting a shared responsibility in the upkeep of SWIS facilities.

Qualitative responses from farmer-beneficiaries further support these findings.

Several respondents stated that the canals and reservoir are still usable, but maintenance is not always conducted regularly. Some farmer-beneficiaries mentioned that desilting of the reservoir is sometimes delayed, which causes reduced water storage and weak water flow during dry periods. Others also noted that they usually help in clearing canals and reporting damages to technical personnel, showing that maintenance activities are often done through cooperation between farmer-beneficiaries and DENR-PENRO personnel. These responses explain why maintenance was generally rated as satisfactory, although concerns about irregular maintenance schedules were still observed. Proper operation and maintenance are essential in sustaining the performance of irrigation and small water impounding systems. In the Philippines, the National Irrigation Administration (NIA, 2018) emphasizes that regular inspection, timely repair, and proper maintenance of canals, dams, and water control structures are necessary to ensure continuous water supply and to prevent deterioration of irrigation facilities. Maintenance activities such as canal clearing, desilting, and structural repair help maintain the efficiency of water distribution systems and support stable agricultural production, particularly in community-based irrigation and water impounding projects.

Maintenance practices include regular facility checks, keeping canals and dam structures in good condition, timely resolution of maintenance issues, and active farmer-beneficiaries participation. These findings are consistent with local irrigation management practices where farmer participation is encouraged to support the sustainability of small-scale irrigation facilities. According to the National Irrigation Administration (2018), the involvement of farmer-beneficiaries in maintenance activities strengthens the sustainability of irrigation systems because users become directly responsible for protecting and maintaining the infrastructure that supports their agricultural livelihood. Despite these favorable aspects, a significant concern emerges regarding the irregular reservoir cleaning and desilting. Sediment accumulation has been identified as a factor disrupting water flow, especially during heavy rainfall events, which indicates inconsistencies in preventive and long-term maintenance across various SWIS sites. Some farmer-beneficiaries reported that when the reservoir is not cleaned regularly, water supply becomes insufficient during dry months, affecting crop production. In the Philippines, sedimentation is a common problem in water impounding structures. The Department of Environment and Natural Resources (DENR, 2019) states that regular desilting and rehabilitation are necessary to maintain the storage capacity of Small Water

Impounding Systems, since accumulated sediments may reduce water supply and affect irrigation performance. Failure to conduct periodic cleaning may result in reduced efficiency and shortened service life of the facility. The lack of systematic scheduling for major maintenance activities, such as desilting, poses a risk to the long-term reliability and efficiency of SWIS. Government guidelines for irrigation and water resource projects in the Philippines emphasize that maintenance should not only focus on minor repairs but should also include periodic major maintenance and rehabilitation to ensure structural stability and operational efficiency (NIA, 2018). Without a structured maintenance schedule, irrigation facilities may gradually deteriorate, resulting in reduced performance and higher repair costs.

The performance of irrigation schemes requires continuous monitoring and supervision. While farmer involvement in maintenance is generally positive, effective system performance also depends on adequate technical support from implementing agencies. Some respondents also mentioned that technical personnel are not always available due to limited manpower, which sometimes delays repair and inspection activities. Local studies on government infrastructure projects indicate that maintenance activities may become inconsistent when there is limited manpower, insufficient funding, or lack of equipment (Reyes, 2020). This shows that farmer participation alone cannot ensure effective maintenance unless it is supported by proper planning, supervision, and institutional assistance. The need for a more systematic approach to maintenance is also reflected in the monitoring requirements of government projects. Monitoring guidelines issued by the Department of Environment and Natural Resources (DENR, 2016) require regular inspection, documentation, and reporting to ensure that environmental and water resource projects remain functional. Proper monitoring records help implementing offices evaluate the condition of facilities and plan necessary repairs, thereby improving the long-term performance of water impounding systems. Geographic Information Systems (GIS) and computerized monitoring tools may also be used to assess infrastructure condition and help prioritize maintenance activities based on actual field conditions.

The perception of SWIS maintenance by farmer-beneficiaries' contrasts with the identified irregularity in reservoir desilting, suggesting a gap in long-term preventive strategies. This indicates the need to strengthen maintenance planning and monitoring procedures in the operation of irrigation facilities. Implementing more organized maintenance schedules, improving documentation, and ensuring regular inspection can help prevent damage and sustain the performance of SWIS. Strengthening coordination between DENR-PENRO Albay technical personnel and farmer-beneficiaries, together with improved monitoring and maintenance planning, is necessary to ensure the continued functionality and reliability of the Small Water Impounding System. System maintenance practices were also assessed from the perspective of DENR-PENRO Albay technical personnel. Table 3 presents the perspectives of DENR-PENRO Albay technical personnel on system maintenance.

Table 3. *Maintenance of the SWIS from the Perspectives of the DENR-PENRO Technical Personnel (N=10)*

Indicators	Weighted Mean	Interpretation
• Routine inspection and maintenance of SWIS structures are regularly conducted.	3.60	Agree
• Maintenance schedules are well-documented and properly implemented.	3.40	Moderately Agree
• Issues such as sedimentation, leakage, or erosion are addressed promptly.	3.50	Agree
• There are sufficient funding and manpower for SWIS maintenance.	3.30	Moderately Agree
• Maintenance reports are consistently submitted and reviewed.	3.20	Moderately Agree
Overall Weighted Mean	3.40	Moderately Agree

Legend: 1.00–1.49 Strongly Disagree; 1.50–2.49 Disagree; 2.50–3.49 Moderately Agree 3.50–4.49 Agree; 4.50–5.00 Strongly Agree

The overall weighted mean of 3.40 shows a similar level of agreement with that of the farmer-beneficiaries, indicating that technical personnel consider system maintenance practices to be generally implemented, although not consistently. While maintenance activities are conducted and monitored, their effectiveness is influenced by practical limitations encountered in field operations. Responses indicate that inspections are usually conducted during the third quarter of the year, during which system conditions are evaluated and documented for appropriate action. Maintenance activities are planned, but actual implementation depends heavily on the availability of manpower and budgetary resources, resulting in periodic rather than continuous inspections.

Qualitative responses from DENR-PENRO Albay technical personnel further explain these results. Some respondents stated that maintenance schedules are prepared, but actual field implementation is sometimes delayed due to limited manpower, lack of equipment, and budget constraints. Technical personnel also mentioned that some SWIS sites are located in remote areas, making it difficult to conduct regular inspection and immediate repair. Others noted that reservoir desilting and major repairs cannot always be done on time because these activities require additional funding and coordination. These responses support the quantitative result showing only a moderate level of agreement on maintenance implementation.

This situation is consistent with maintenance practices in irrigation and water resource projects in the Philippines, where limited personnel and financial resources often affect the regularity of inspection and repair activities. According to the National Irrigation Administration (2018), proper maintenance of irrigation and water impounding systems requires adequate manpower, sufficient funding, and regular inspection schedules to ensure that facilities remain functional and safe. When these resources are insufficient, maintenance activities may become irregular, which can affect the efficiency and reliability of the system. Additional challenges identified by technical personnel include outdated equipment, limited transportation, and difficulty in accessing remote SWIS sites. These constraints reduce the ability to conduct frequent inspections and immediate repairs. Similar observations were reported in local studies on government infrastructure projects, where maintenance activities are sometimes delayed due to lack of logistical support and limited operational funds (Reyes, 2020). These conditions explain why maintenance effectiveness is rated only at a moderate level despite the presence of monitoring and reporting procedures.

To improve the consistency and sustainability of SWIS operations, strengthening institutional support and implementing more systematic preventive maintenance strategies are necessary. Monitoring guidelines for environmental and water resource projects in the Philippines require regular inspection, documentation, and reporting to ensure that facilities remain functional (DENR, 2016). Proper monitoring records help technical personnel identify maintenance needs early and plan repair activities before serious damage occurs.

Technical personnel also noted that Geographic Information Systems (GIS) are currently being used in monitoring SWIS sites, but the existing system is limited in capability. Although GIS allows basic documentation of project locations, it does not yet provide advanced features such as real-time monitoring, automated analysis, and integrated reporting. Respondents suggested that improved monitoring tools and digital systems could help in tracking the condition of SWIS facilities and in planning maintenance activities more efficiently. In government projects in the Philippines, the use of computerized monitoring systems is recommended to improve data management, reporting, and coordination among implementing offices (DENR, 2016). While farmer-beneficiaries participation remains an important factor in maintaining SWIS facilities, long-term sustainability also depends on strong institutional support, adequate funding, and effective monitoring systems. Both quantitative results and qualitative responses indicate that maintenance activities are implemented but not always consistent due to operational constraints. Strengthening maintenance planning, improving monitoring procedures, and providing sufficient manpower and equipment are necessary to ensure the continued functionality and reliability of the Small Water Impounding System.

Water Distribution

Water distribution practices under the Small Water Impounding System (SWIS) were assessed to determine whether water is delivered consistently to farmer-beneficiaries. Based on the responses, water distribution is generally perceived as satisfactory and supportive of agricultural activities. Most farmer-beneficiaries indicated that water supplied through SWIS reaches their farms and is sufficient for crop production, particularly during regular planting seasons. Despite the generally favorable assessment, some farmer-beneficiaries experienced intermittent water interruptions and unequal distribution, especially during periods of limited water availability such as dry seasons. These concerns suggest that while water distribution mechanisms are in place, their effectiveness varies depending on environmental conditions and scheduling practices. Table 4 presents the perspectives of the farmer-beneficiaries on water distribution.

Table 4. *Water Distribution Practices from the Perspectives of the Farmer Beneficiaries (N=20)*

Indicators	Weighted Mean	Interpretation
• The water from SWIS is distributed fairly among farmers.	3.75	Agree
• The volume of water provided is sufficient for crop requirements.	3.85	Agree
• The schedule of water release is well-coordinated and followed	3.60	Agree
Overall Weighted Mean	3.73	Agree

Legend: 1.00–1.49 Strongly Disagree; 1.50–2.49 Disagree; 2.50–3.49 Moderately Agree; 3.50–4.49 Agree; 4.50–5.00 Strongly Agree

The overall weighted mean of 3.73 indicates that farmer-beneficiaries generally agree that water distribution under SWIS is effective. This implies that the system largely meets irrigation needs and contributes positively to farming operations. Most farmer-beneficiaries confirmed that water from SWIS reaches their farms and is sufficient for crop production. The fairness of water distribution, the adequacy of water volume, and the coordination of water release schedules all received Agree ratings, suggesting that the SWIS irrigation system generally fulfills farming requirements.

Qualitative responses from farmer-beneficiaries support these findings. Several respondents stated that water from the reservoir usually reaches their farms, but during dry months the water level becomes low and distribution becomes limited. Some farmers-beneficiaries mentioned that upstream farms sometimes receive water earlier than those located farther from the canal, which causes unequal distribution during periods of shortage. Others also noted that they are not always informed in advance when water release schedules change, especially during sudden weather changes. These responses explain why water distribution was rated as satisfactory but still showed some limitations in scheduling and fairness.

Effective water distribution is a key factor in the success of irrigation and water impounding systems. In the Philippines, the National Irrigation Administration (2018) states that water allocation should follow approved schedules based on available supply, system capacity, and the needs of farmer-beneficiaries to ensure fair and efficient distribution. Proper coordination of water release schedules helps prevent conflicts among users and ensures that irrigation systems continue to support agricultural production.

While the sufficiency of water supplied generally supports crop requirements and agricultural production, fairness in distribution reflects the extent to which the system provides equitable access among farmers-beneficiaries. Fairness and adequacy, however, may be affected when water supply becomes limited, particularly during dry seasons when schedule adjustments are necessary. Such conditions can result in short-term disparities in access to water among users. In irrigation projects in the Philippines, unequal distribution may occur when reservoir storage is low or when schedules are not strictly followed, which may affect crop production of some beneficiaries (NIA, 2018). These findings emphasize that the fairness and sufficiency of water allocation directly influence the overall effectiveness of water distribution,

as unequal or insufficient allocation may limit the ability of the SWIS to fulfill its primary objective of providing reliable and equitable water supply for agricultural production.

Despite the generally positive perceptions, some farmer-beneficiaries reported intermittent water interruptions during periods of scarcity, which were associated with reduced water availability and unclear or poorly communicated schedules. It is important to note that the assessment of distribution fairness is based on the perceptions of respondents who were available during the data collection period. As such, these findings primarily reflect perceived fairness among participating beneficiaries and may not fully capture the experiences of all users served by the SWIS. This suggests that while the results provide valuable insights into water distribution practices, the adequacy and equity of water allocation across the entire beneficiary population may require broader participation in future evaluations.

The need for improvements in scheduling, communication, and contingency planning is also supported by qualitative responses. Some farmer-beneficiaries suggested that clearer schedules and earlier announcements of water release would help them prepare their farming activities. Others recommended more frequent maintenance of canals to improve water flow. In irrigation and water impounding projects in the Philippines, proper communication between implementing agencies and farmer-beneficiaries is necessary to ensure efficient water distribution and prevent misunderstanding among users (Reyes, 2020). Regular maintenance of canals and reservoirs is also required to maintain sufficient water supply, particularly during dry seasons (DENR, 2019).

Likewise, the DENR-PENRO technical personnel were all in agreement with the indicators reflected in Table 5 regarding water distribution and resource utilization.

Table 5. *Water Distribution and Resource Utilization from the Perspectives of the DENR-PENRO Technical Personnel (N=10)*

Indicators	Weighted Mean	Interpretation
• Water allocation plans are based on technical assessment and community needs.	3.80	Agree
• Water delivery systems are efficient and minimize wastage.	3.70	Agree
• Farmers are properly informed of water schedules and maintenance activities.	3.60	Agree
• SWIS operations support both agricultural and environmental objectives.	3.70	Agree
Overall Weighted Mean	3.70	Agree

Legend: 1.00–1.49 Strongly Disagree; 1.50–2.49 Disagree; 2.50–3.49 Moderately Agree; 3.50–4.49 Agree; 4.50–5.00 Strongly Agree

The results show an overall weighted mean of 3.70, suggesting that technical personnel perceive water distribution practices as effective, although influenced by external factors such as weather variability and administrative coordination. While distribution mechanisms are operational, adjustments are often required when water supply becomes limited. Coordination challenges with farmer-beneficiaries, particularly during sudden schedule changes caused by weather conditions, further affect the efficiency of water distribution. Qualitative responses from technical personnel indicated that water allocation plans are usually prepared based on available water level and number of beneficiaries, but sudden changes in weather conditions sometimes require immediate adjustment of schedules. Some respondents also stated that informing all farmer-beneficiaries at once is difficult, especially when sites are far from each other. Others mentioned that limited manpower makes it hard to monitor water distribution in all SWIS locations at the same time. These responses explain why communication and coordination indicators received only moderate agreement.

These findings are consistent with irrigation management practices in the Philippines, where water allocation should be based on technical assessment, reservoir capacity, and community needs (National

Irrigation Administration, 2018). Proper planning and coordination are necessary to maintain fairness in water distribution, especially in small water impounding systems where supply depends on rainfall and reservoir storage. Effective communication between technical personnel and farmer-beneficiaries is therefore essential to ensure that water schedules are followed and adjusted when necessary.

The results also show agreement that the benefits of SWIS are maximized for both irrigation and reforestation purposes. This indicates that respondents recognize the role of SWIS not only in supporting agricultural water needs but also in contributing to environmental programs such as the National Greening Program (NGP). The availability of water from SWIS supports the establishment and maintenance of seedlings used in reforestation projects, particularly during dry periods when natural water sources are limited. According to DENR (2016), water impounding systems are important support facilities in environmental rehabilitation programs because they provide water needed for both agricultural production and forest plantation maintenance. This demonstrates that SWIS contributes to integrated resource management by supporting both agricultural and environmental objectives. However, areas requiring improvement were identified, particularly in coordination with farmer-beneficiaries and in the communication of water schedules and maintenance activities. Sudden changes in water availability, often caused by weather variability, require adjustments in distribution plans, which are not always communicated promptly. These communication gaps limit optimal water utilization, especially during periods of scarcity. Local studies on irrigation projects show that weak communication and limited monitoring may result in unequal distribution and reduced system efficiency (Reyes, 2020). To enhance the effectiveness of SWIS operations and resource utilization, strengthening communication, improving scheduling procedures, and adopting more systematic monitoring methods are necessary. Monitoring and reporting systems used in government environmental projects help improve coordination and decision-making by providing updated information on system condition and water availability (DENR, 2016). The use of improved monitoring tools can therefore enhance the reliability, sustainability, and overall performance of SWIS water distribution.

Resource Utilization

Resource utilization under the Small Water Impounding System (SWIS) was assessed to determine how effectively available resources particularly water, infrastructure, and operational support are used to enhance agricultural productivity and support the livelihood of farmer-beneficiaries. From the farmers' perspective, resource utilization is generally viewed as effective and beneficial, as SWIS operations contribute directly to improved irrigation access, crop management, and farming efficiency. Most farmer-beneficiaries reported that the water supplied through SWIS allows them to maximize land use, cultivate crops more consistently, and reduce dependence on rainfall. As users of the system, farmers-beneficiaries recognized that proper utilization of SWIS resources enables them to plan planting schedules more efficiently and sustain crop growth even during periods of variable weather conditions. Table 6 presents their responses.

Table 6. *Resource Utilization Practices from the Perspectives of the Farmer Beneficiaries (N=20)*

Indicators	Weighted Mean	Interpretation
• The SWIS benefits are maximized for both irrigation and reforestation purposes.	4.00	Agree
• The operation of SWIS helps improve agricultural yield and productivity.	3.95	Agree
• Farmers understand how SWIS functions and its role in the community.	3.90	Agree
• The community contributes to sustaining the SWIS operation.	3.95	Agree
Overall Mean	3.95	Agree

Legend: 1.00–1.49 Strongly Disagree; 1.50–2.49 Disagree; 2.50–3.49 Moderately Agree; 3.50–4.49 Agree; 4.50–5.00 Strongly Agree

A weighted mean of 3.95 indicates that farmer-beneficiaries agree that SWIS resources are effectively utilized. This high rating reflects the perceived contribution of the system to increased productivity and improved farming outcomes. SWIS resources significantly contribute to improved irrigation access, increased agricultural productivity, and sustained farming activities. Farmer-beneficiaries reported that enhanced water availability allows more efficient land use, better crop planning, and reduced reliance on unpredictable rainfall patterns. A common benefit cited by farmers is the ability to conduct multiple cropping cycles within a year, which directly contributes to improved livelihood stability.

Qualitative responses from farmer-beneficiaries support these results. Several respondents stated that because of the water provided by SWIS, they are able to plant regularly even during dry periods, which helps increase crop yield and income. Some farmer-beneficiaries mentioned that before the construction of SWIS, farming depended mostly on rainfall, but now they can schedule planting more confidently. Others also noted that the system helps not only in irrigation but also in watering newly planted trees under reforestation activities. However, a few respondents expressed concerns that during peak planting seasons, water supply sometimes becomes limited, especially for farms located far from the main canal. These responses explain why resource utilization was rated high but still showed minor concerns regarding water allocation.

Efficient utilization of irrigation resources is essential in improving agricultural productivity. In the Philippines, irrigation and water impounding systems are established to provide reliable water supply that allows farmer-beneficiaries to cultivate crops regularly and reduce dependence on rainfall. The National Irrigation Administration (2018) states that effective use of irrigation facilities increases cropping intensity, improves yield, and supports the livelihood of farmer-beneficiaries, especially in areas with limited natural water sources. Proper utilization of available water and infrastructure helps ensure that irrigation systems continue to benefit farming communities.

The positive perception of SWIS resource utilization also reflects the importance of proper system operation and community participation. Qualitative responses show that farmer-beneficiaries are willing to help in maintaining canals, reporting damages, and following water schedules to keep the system functional. In irrigation projects in the Philippines, participation of beneficiaries is encouraged to sustain the operation of small-scale irrigation facilities. According to the National Irrigation Administration (2018), active involvement of farmers in system operation and maintenance helps ensure that resources are used properly and that the benefits of irrigation projects are shared among users.

The results further show that SWIS supports not only irrigation but also environmental activities such as reforestation, indicating that resource utilization extends beyond agricultural purposes. Some respondents stated that water from SWIS is also used to support tree planting activities, especially during dry months when natural water sources are limited. In the Philippines, water impounding systems are often integrated with environmental programs. According to the Department of Environment and Natural Resources (2016), SWIS established under the National Greening Program helps maintain planted seedlings by providing water needed for survival and growth, particularly during periods of low rainfall. This demonstrates that effective utilization of SWIS resources contributes both to agricultural production and environmental conservation.

Despite the generally positive perceptions, some farmer-beneficiaries expressed concerns regarding water allocation during periods of high demand. Respondents noted that during peak planting season, water supply may not be enough for all users, and farms located farther from the canal sometimes receive less water. Such challenges are common in irrigation systems where water supply becomes limited and distribution must be carefully managed. In irrigation projects in the Philippines, unequal water allocation may occur when reservoir storage is low or when monitoring of distribution is limited (NIA, 2018). These conditions highlight the importance of proper scheduling, monitoring, and coordination to ensure fair and efficient use of available resources.

Weak coordination and limited supervision may also affect resource utilization. Some respondents mentioned that when schedules are not clearly announced, farmer-beneficiaries may use more water than needed, which affects others. Local studies on government irrigation projects indicate that lack of communication and limited monitoring may lead to inefficient use of water resources (Reyes, 2020). Even when facilities are functional, insufficient coordination between technical personnel and beneficiaries may reduce the overall effectiveness of the system.

To further enhance the effectiveness and equity of SWIS resource utilization, improvements in planning, scheduling, and monitoring are necessary. Respondents suggested that clearer water schedules, regular monitoring, and faster response to reported problems would help improve system performance. Monitoring guidelines for government environmental projects require proper documentation, reporting, and coordination to ensure that resources are used efficiently (DENR, 2016). The use of improved monitoring tools and better record management can help technical personnel track system condition, identify problems early, and plan maintenance activities more effectively.

Farmer-beneficiaries generally perceive SWIS resource utilization as effective and beneficial for agricultural productivity and livelihood improvement. However, concerns related to water allocation during periods of high demand indicate the need for more systematic management and monitoring. Strengthening coordination among farmer-beneficiaries, improving scheduling procedures, and adopting more organized monitoring tools will help ensure that SWIS resources are used efficiently, equitably, and sustainably. These improvements are necessary to support the long-term functionality of the Small Water Impounding System and to maintain its contribution to both agricultural production and environmental programs.

Monitoring and Evaluation

DENR-PENRO Albay technical personnel, acknowledged that SWIS resources are strategically allocated and managed to support irrigation and agricultural production. However, they emphasized that optimal utilization is hindered by limited funding, insufficient manpower, and outdated equipment. Table 7 presents the frequency distribution of responses of DENR-PENRO Albay technical personnel on Monitoring and Evaluation.

Table 7. *Monitoring and Evaluation from the Perspectives of the DENR-PENRO Technical Personnel (N=10)*

Indicators	Weighted Mean	Interpretation
• Monitoring activities are conducted at least once per year.	3.70	Agree
• Performance data are analyzed to guide decision-making	3.60	Agree
• Monitoring results are shared with stakeholders.	3.40	Moderately Agree
• The monitoring process allows identification of operational gaps and best practices.	3.80	Agree
Overall	3.63	Agree

Legend: 1.00–1.49 Strongly Disagree; 1.50–2.49 Disagree; 2.50–3.49 Moderately Agree; 3.50–4.49 Agree; 4.50–5.00 Strongly Agree

A weighted mean of 3.63, interpreted as agree, indicates that monitoring and evaluation mechanisms are present and functional, although their effectiveness is influenced by institutional and operational constraints. Monitoring activities are conducted at least once per year, allowing technical personnel to assess the physical condition, operational status, and overall performance of SWIS facilities. Periodic monitoring is important in water resource projects because it helps identify structural issues, evaluate system efficiency, and determine whether facilities continue to operate as intended.

Qualitative responses from technical personnel further explain these results. Some respondents stated that monitoring is usually conducted once a year due to limited manpower and budget, and additional

inspections are only done when problems are reported. Others mentioned that monitoring reports are prepared after site visits, but follow-up actions may be delayed when funds or equipment are not immediately available. Some personnel also noted that monitoring several SWIS sites at the same time is difficult because of distance and limited transportation. These responses explain why monitoring activities are implemented but not always done regularly.

Monitoring and evaluation are required in government infrastructure and environmental projects in the Philippines to ensure that facilities remain functional and that project objectives are achieved. Monitoring guidelines issued by the Department of Environment and Natural Resources (2016) require regular field inspection, documentation, and reporting to evaluate the condition of project sites and to guide maintenance and improvement activities. Proper monitoring helps implementing offices determine whether projects are performing according to plan and identify the actions needed to sustain their operation.

The results also show agreement that performance data are analyzed to guide decision-making, indicating that monitoring activities are used as a basis for planning maintenance, repairs, and operational adjustments. Technical personnel reported that inspection results are used to prepare maintenance plans and reports submitted to higher offices. In irrigation and water resource projects in the Philippines, the National Irrigation Administration (2018) emphasizes that monitoring reports and performance records are necessary to support planning, budgeting, and repair activities. Accurate data allow implementing agencies to prioritize maintenance and allocate resources where they are most needed.

The monitoring process was also perceived to be effective in identifying operational gaps and best practices, as reflected in the highest weighted mean among the indicators. Monitoring serves as a diagnostic tool that helps determine whether the system is functioning properly and what improvements are needed. Some respondents stated that site inspections help them detect sedimentation problems, damaged canals, or leakage that require repair. In government water resource projects, regular monitoring is necessary to prevent small problems from becoming major structural issues that may affect the reliability of the system (DENR, 2016).

Despite these strengths, the sharing of monitoring results with stakeholders received only a neutral rating, indicating that dissemination of information is not always consistent. Qualitative responses show that monitoring results are usually reported to the office, but not always explained to farmer-beneficiaries unless there is a meeting or repair activity. Some personnel stated that time limitations make it difficult to discuss monitoring results with all beneficiaries. Limited communication of monitoring results may reduce transparency and restrict the participation of farmer-beneficiaries in maintenance and water management activities. Local studies on government irrigation projects show that when beneficiaries are not informed about system condition and plans, cooperation may decrease and misunderstandings in water distribution may occur (Reyes, 2020).

The results also suggest that institutional limitations affect the effectiveness of monitoring and evaluation activities. Technical personnel reported that monitoring is conducted regularly, but the frequency and depth of assessment depend on available manpower, budget, and equipment. Some respondents mentioned that lack of transportation, insufficient monitoring tools, and limited personnel make it difficult to conduct frequent inspections. Similar conditions are observed in government infrastructure projects in the Philippines, where monitoring activities may become irregular when resources are limited (NIA, 2018). Adequate institutional support is therefore necessary to ensure that monitoring activities are not only conducted but also used effectively in improving project performance.

Improving monitoring and evaluation practices requires stronger feedback mechanisms between technical personnel and farmer-beneficiaries. Respondents suggested that monitoring results should be shared more often with farmer-beneficiaries so that they can understand the condition of the system and help in reporting problems. Monitoring guidelines for government projects recommend proper documentation, reporting, and coordination among stakeholders to improve project supervision (DENR,

2016). When information is shared regularly, cooperation between technical personnel and beneficiaries becomes stronger, which helps improve maintenance and water distribution.

Technical personnel also mentioned that monitoring records are currently prepared manually, and they suggested that improved monitoring tools or computerized systems would help make reporting easier and faster. The use of organized data management systems can help track inspection results, maintenance schedules, and repair needs more efficiently. In government environmental projects, proper record management and monitoring systems help improve coordination among offices and allow faster decision-making (DENR, 2016).

Enhancing communication, strengthening stakeholder involvement, and improving documentation procedures can increase the effectiveness of monitoring and evaluation in SWIS operations. More systematic monitoring supported by organized reporting and proper coordination will help technical personnel identify operational gaps more accurately, improve cooperation with farmer-beneficiaries, and ensure that the Small Water Impounding System continues to provide reliable support for agricultural production and environmental programs.

Performance Gaps in the Implementation of Small Water Impounding System (SWIS)

Performance gaps in the implementation of the Small Water Impounding System (SWIS) were assessed based on the adequacy of monitoring guidelines, coordination, data management, and the contribution of monitoring to water management goals. The perspectives of both farmer-beneficiaries and DENR–PENRO Albay technical personnel are presented in Table 8.

As shown in Table 8, both groups generally agreed that performance gaps exist in the implementation of SWIS. Farmer-beneficiaries obtained an overall weighted mean of 3.60, while DENR technical personnel recorded a higher overall weighted mean of 4.20, both interpreted as Agree. This indicates that although monitoring-related mechanisms are present, certain limitations remain in the current monitoring and management processes of SWIS.

For the indicator “Current monitoring guidelines sufficiently capture the performance of SWIS,” farmer-beneficiaries gave a weighted mean of 3.50, while technical personnel rated it slightly higher at 3.80, both interpreted as Agree. This suggests that existing monitoring guidelines are generally considered functional, although improvements may still be necessary to fully capture the operational performance of SWIS projects.

Table 8. *Performance Gaps from the Perspectives of the Farmer-beneficiaries and DENR-PENRO Technical Personnel*

Indicators	Farmer-beneficiaries (N=20)		DENR-PENRO Tech. Personnel (N=10)	
	WM	Intrprtatn	WM	Intrprtatn
• Current monitoring guidelines sufficiently capture the performance of SWIS.	3.50	Agree	3.80	Agree
• There is a need for updated or refined monitoring tools	3.60	Agree	4.50	Strongly Agree
• The current data management system supports accurate and timely reporting	3.55	Agree	4.10	Agree
• Coordination among DENR Technical personnel is efficient	3.60	Agree	4.20	Strongly Agree
• SWIS monitoring contributes to the achievement of NGP and water management goals	3.75	Agree	4.40	Strongly Agree
Overall Mean	3.60	Agree	4.20	Agree

Legend: 1.00–1.49 Strongly Disagree; 1.50–2.49 Disagree; 2.50–3.49 Moderately Agree 3.50–4.49 Agree; 4.50–5.00 Strongly Agree

Qualitative responses support this finding, as some farmer-beneficiaries stated that monitoring activities are conducted but they are not always informed about the results or the condition of the system after inspection. Some respondents mentioned that problems in canals or reservoirs are sometimes reported but not immediately resolved. Technical personnel also noted that monitoring guidelines exist, but their implementation depends on available manpower, budget, and schedule. These responses explain why monitoring was considered functional but still needing improvement.

Monitoring guidelines are required in government environmental and water resource projects in the Philippines to ensure that facilities are properly implemented and maintained. According to the Department of Environment and Natural Resources (2016), regular inspection, documentation, and reporting are necessary to evaluate project performance and to guide maintenance and rehabilitation activities. When monitoring procedures are not fully implemented, the accuracy of performance evaluation may be affected.

Both groups also recognized the need for updated or refined monitoring tools, with farmer-beneficiaries giving a weighted mean of 3.60 (Agree) and technical personnel indicating a stronger perception with 4.50 (Strongly Agree). The stronger agreement among technical personnel suggests that those directly involved in monitoring activities are more aware of the limitations of existing monitoring tools and procedures used in assessing SWIS performance.

Qualitative responses from technical personnel indicate that monitoring is mostly done manually, and reports are prepared using basic forms, which sometimes makes data recording slow and difficult to organize. Some respondents suggested the use of computerized monitoring systems or standardized forms to make reporting easier and faster. In government projects in the Philippines, improved monitoring tools and data management systems are recommended to ensure accurate reporting and better supervision, especially when multiple project sites are involved (Reyes, 2020).

In terms of data management, farmer-beneficiaries rated the statement “The current data management system supports accurate and timely reporting” with a weighted mean of 3.55 (Agree), while technical personnel rated it higher at 4.10 (Agree). This indicates that although systems for data management are present, improvements may still be needed to ensure more efficient reporting and better utilization of monitoring data.

Some respondents noted that reports are submitted regularly, but consolidation of data from different SWIS sites sometimes takes time. Technical personnel also mentioned that limited monitoring tools and lack of digital recording systems make it difficult to track all projects efficiently. In irrigation and water resource projects in the Philippines, proper record keeping and updated reports are required to support planning, budgeting, and maintenance activities (National Irrigation Administration, 2018). Accurate data management helps ensure that decisions are based on actual field conditions.

For coordination among DENR technical personnel, farmer-beneficiaries reported a weighted mean of 3.60 (Agree), while technical personnel provided a higher rating of 4.20 (Strongly Agree). While coordination is generally perceived as effective within the agency, the difference in ratings may indicate that coordination mechanisms are not always fully visible to farmer-beneficiaries.

Qualitative responses show that coordination among technical personnel is present, but communication with farmer-beneficiaries is sometimes limited, especially when monitoring activities are done quickly or when personnel have to visit several sites in one schedule. Some farmer-beneficiaries stated that they are only informed when there is a repair or problem, but not always during monitoring activities. In irrigation projects in the Philippines, effective coordination and communication between implementing agencies and beneficiaries are necessary to ensure proper operation and maintenance of irrigation systems (NIA, 2018).

Both groups also acknowledged that SWIS monitoring contributes to the achievement of National Greening Program (NGP) and water management goals, with farmer-beneficiaries giving a weighted mean of 3.75 (Agree) and technical personnel rating it 4.40 (Strongly Agree). This reflects recognition of the

broader role of SWIS not only in supporting irrigation but also in contributing to environmental and watershed management initiatives.

Some respondents mentioned that SWIS helps in watering planted trees and maintaining reforestation areas, especially during dry months. Technical personnel also stated that SWIS projects are monitored together with NGP activities to ensure that both irrigation and environmental objectives are achieved. According to DENR (2016), water impounding systems established under environmental programs are intended to support both agricultural production and forest rehabilitation, making monitoring important for both purposes.

Despite these generally positive assessments, the results indicate several performance gaps in SWIS implementation, particularly in the areas of monitoring tools, communication, and stakeholder engagement. Farmer-beneficiaries emphasized the need for clearer communication and more regular updates regarding maintenance schedules, monitoring results, and water distribution plans. Some respondents mentioned that lack of information sometimes causes misunderstanding about water allocation or repair activities.

Technical personnel also highlighted operational constraints affecting monitoring effectiveness, including limited manpower, insufficient funding, and lack of monitoring equipment. Because of these limitations, monitoring activities are sometimes done only once a year or only when problems occur. Similar conditions are observed in government infrastructure projects in the Philippines, where limited resources affect the regularity of monitoring and reporting (Reyes, 2020).

To address these performance gaps, strengthening participatory monitoring, improving communication channels, and enhancing monitoring tools are necessary. Respondents suggested that monitoring results should be shared more often with farmer-beneficiaries and that they should also be encouraged to report problems immediately. Monitoring guidelines for government projects recommend proper coordination, reporting, and feedback among stakeholders to improve project implementation (DENR, 2016).

The results indicate that although monitoring mechanisms for SWIS are already in place, improvements are still needed in monitoring tools, coordination processes, and stakeholder engagement to address the operational limitations identified by both farmer-beneficiaries and DENR–PENRO Albay technical personnel. Strengthening monitoring procedures, improving communication, and providing adequate resources will help ensure more effective and sustainable implementation of the Small Water Impounding System.

Open-Ended Responses to enhance monitoring guidelines for performance evaluation and continuous improvement

The open-ended responses from both farmer-beneficiaries and DENR–PENRO Albay technical personnel provided deeper insights into the operational condition of the Small Water Impounding System (SWIS) and helped explain the results obtained from the quantitative data. The responses revealed recurring concerns related to maintenance, water distribution, monitoring practices, and institutional limitations, indicating the need for improved monitoring guidelines and the development of a more systematic and innovative monitoring tool for performance evaluation.

One of the most common issues raised by farmer-beneficiaries is the irregular maintenance of reservoirs and canals. Several respondents stated that desilting and cleaning activities are not conducted regularly, which affects the storage capacity of the reservoir and the flow of water to their farms. One respondent stated, *“Sometimes the reservoir is not cleaned immediately, so during the rainy season it becomes filled with sediments and less water reaches our farms.”* Another farmer-beneficiary mentioned, *“When the canal is damaged and not repaired right away, it becomes difficult for us to get enough water, especially during the dry season.”* These responses indicate that delayed maintenance directly affects water availability and agricultural productivity. This finding is consistent with studies on irrigation and water impounding systems in the Philippines, which emphasize that regular

maintenance, including desilting and canal repair, is necessary to maintain the efficiency of water facilities (National Irrigation Administration, 2018). The Bureau of Soils and Water Management (2017) also reported that sediment accumulation and lack of preventive maintenance reduce the storage capacity of small water impounding projects, resulting in inconsistent irrigation supply. These findings imply that the absence of a structured monitoring system for maintenance contributes to operational inefficiency.

Another concern expressed by farmer-beneficiaries relates to communication and coordination. Some respondents stated that they are not always informed about water release schedules or maintenance activities. One respondent said, *“We are not always informed about the water release schedule, so irrigation is sometimes not properly coordinated.”* Another respondent mentioned, *“It would be better if there were regular meetings so that we know the plans and schedules for the SWIS.”* These responses suggest that limited communication affects the fairness and efficiency of water distribution.

Previous studies on participatory irrigation management showed that proper coordination between implementing agencies and beneficiaries improves system performance and reduces conflicts in water allocation (Rola, 2019). When farmers are informed and involved in monitoring activities, cooperation increases and the system becomes more sustainable. These findings indicate that monitoring guidelines should include regular consultation, feedback mechanisms, and community participation.

From the perspective of DENR-PENRO Albay technical personnel, several operational constraints were identified that affect monitoring effectiveness. Respondents mentioned limited manpower, insufficient budget, and lack of monitoring equipment. One technical personnel stated, *“We cannot monitor all SWIS sites regularly because we have limited personnel and the sites are far from each other.”* Another respondent explained, *“Monitoring is conducted, but sometimes only once a year because of limited funds and lack of transportation.”* These responses indicate that monitoring activities are present but are not continuous due to resource limitations.

Similar findings were reported in studies on government irrigation and environmental projects in the Philippines, where limited personnel, budget constraints, and logistical difficulties affect the regularity of monitoring and maintenance activities (Reyes, 2020). Monitoring guidelines issued by the Department of Environment and Natural Resources (2016) emphasize that regular inspection, documentation, and reporting are necessary to ensure that water resource and environmental projects remain functional. When monitoring is irregular, operational problems may not be detected early, leading to reduced system performance.

Both farmer-beneficiaries and technical personnel also suggested improvements in monitoring procedures. Respondents recommended clearer monitoring guidelines, regular inspection schedules, proper recording of monitoring results, and the use of modern tools to make monitoring more efficient. One technical personnel stated, *“Monitoring would be more effective if there is a system where we can record data and easily see the status of every SWIS.”* Another respondent added, *“It would be helpful if there is a dashboard or computerized system that shows the condition of each site.”* These responses highlight the need for a more organized and technology-supported monitoring framework.

The use of information systems in irrigation and water resource management has been recommended to improve monitoring, reporting, and decision-making (AMTEC, 2017). Monitoring systems supported by computerized databases or dashboard platforms allow technical personnel to track project performance, identify problems early, and plan maintenance activities more efficiently. The responses of the participants indicate that the current monitoring method is mostly manual and needs improvement to support continuous performance evaluation.

Based on these findings, the study recommended the development of an innovative monitoring tool in the form of a SWIS Monitoring Dashboard to support performance evaluation and continuous improvement. The proposed dashboard will serve as a centralized monitoring platform where technical personnel can record inspection results, maintenance schedules, water distribution status, and operational

issues for each SWIS site. The system will also improve coordination among technical personnel and farmer-beneficiaries by providing organized and accessible information, allowing faster reporting and better decision-making.

The adoption of a dashboard-based monitoring system, together with enhanced participatory monitoring guidelines, will address the problems identified by both farmer-beneficiaries and technical personnel. Strengthening maintenance monitoring, improving communication, and organizing monitoring data will enhance the effectiveness, transparency, and sustainability of SWIS implementation in DENR-PENRO Albay, while supporting continuous performance evaluation and long-term water resource management.

CONCLUSIONS

This study examined the monitoring guidelines and implementation performance of the Small Water Impounding System (SWIS) under DENR-PENRO Albay in support of sustainable water resource management, agricultural productivity, and the objectives of the National Greening Program. The findings confirm that SWIS plays an important role in providing a stable water source for irrigation and reforestation activities, which contributes to community resilience and environmental sustainability in the province. However, the effectiveness of the system depends on proper operation, maintenance, and monitoring.

Results showed that operational practices in terms of system maintenance, water distribution, and resource utilization were generally interpreted as Agree, while some indicators, particularly from the perspective of technical personnel, were rated as Moderately Agree. These findings indicate that the SWIS units remain functional and beneficial to farmer-beneficiaries, but maintenance activities such as reservoir desilting, canal repair, and regular inspection are not always consistently implemented due to limited manpower, insufficient funding, and difficult site accessibility.

Water distribution practices were also interpreted as Agree, showing that the system generally provides sufficient water for farming and reforestation purposes. However, concerns on unequal distribution, interruptions during dry periods, and limited communication of schedules indicate the need for better coordination between technical personnel and farmer-beneficiaries. Resource utilization was likewise interpreted as Agree, confirming that SWIS supports both agricultural production and environmental programs, although its efficiency depends on proper supervision, scheduling, and monitoring.

Monitoring and evaluation practices were interpreted as Agree, indicating that monitoring activities are conducted but are mostly periodic rather than continuous. Limited manpower, budget constraints, and lack of updated monitoring tools affect the consistency of inspection, reporting, and follow-up actions. In addition, monitoring results are not always communicated to beneficiaries, which limits participation and timely response to operational problems.

The study also identified performance gaps in the current monitoring guidelines, particularly in maintenance planning, communication, data management, and monitoring procedures. These gaps show that existing monitoring practices are not sufficient to fully support the long-term sustainability of SWIS projects under DENR-PENRO Albay.

Based on these findings, it is concluded that although the Small Water Impounding System in Albay is generally functional as indicated by Agree ratings, strengthening the monitoring system is necessary to ensure continuous performance evaluation and effective water resource management. The development of structured monitoring guidelines and a dashboard-based monitoring tool is recommended to improve maintenance planning, enhance coordination, support decision-making, and promote the sustainable operation of SWIS in support of agriculture, reforestation, and environmental protection.

Recommendations

Based on the findings and conclusions of the study on the monitoring guidelines for DENR-PENRO Albay's Small Water Impounding System (SWIS), the following recommendations are proposed to address identified performance gaps and enhance the effectiveness, transparency, and sustainability of SWIS implementation. These recommendations are aligned with the mandate of DENR-PENRO in environmental management, water resource governance, and community-based project implementation.

1. DENR-PENRO Albay should review and update existing SWIS monitoring guidelines to ensure they are responsive to current operational and environmental conditions. The study revealed that while monitoring activities are conducted, variations in monitoring procedures and the absence of clearly defined performance indicators limit the use of monitoring results for decision-making. Standardized monitoring tools, clear indicators, and uniform reporting formats will improve data accuracy and comparability across SWIS sites, thereby supporting evidence-based management and timely corrective actions.

2. A regular and preventive maintenance schedule should be institutionalized, with particular emphasis on reservoir desilting, canal clearing, and structural inspection. DENR-PENRO Albay, in coordination with local stakeholders, should develop annual maintenance plans that clearly identify responsibilities, timelines, and resource requirements. Preventive maintenance will reduce system deterioration, minimize emergency repairs, and enhance long-term system reliability.

3. DENR-PENRO Albay should strengthen coordination with farmer-beneficiaries by establishing regular consultation meetings, clear communication, and designated focal persons at the community level. Effective water distribution and system sustainability depend on timely information sharing, clear communication of water schedules, and regular consultations. Improved coordination mechanisms can enhance farmer-beneficiaries compliance, reduce conflicts, and promote shared responsibility in system operation and maintenance.

4. Farmer-beneficiaries should be actively involved in SWIS monitoring through participatory approaches such as community-based monitoring teams, reporting mechanisms for system issues, and feedback sessions on monitoring outcomes. Involving farmer-beneficiaries in monitoring activities will enhance their sense of ownership, improve compliance with operational guidelines, and strengthen collaboration between beneficiaries and technical personnel. Active participation of farmer-beneficiaries not only complements technical monitoring efforts but also enhances accountability and long-term sustainability through shared decision-making.

5. DENR-PENRO Albay should establish a centralized and standardized data management system for SWIS monitoring. This system should allow for systematic recording, storage, and analysis of monitoring data, including maintenance records, inspection results, and performance indicators. Improved data utilization will support planning, budgeting, and performance evaluation, enabling DENR-PENRO Albay to respond more effectively to system issues and resource constraints.

6. To address constraints identified by technical personnel, DENR-PENRO Albay should advocate for increased budget allocation, additional manpower, and upgraded monitoring equipment. Investments in modern monitoring tools and adequate staffing are essential for improving the frequency, accuracy, and coverage of monitoring activities across multiple SWIS sites.

7. Regular training programs should be conducted for DENR-PENRO Albay technical personnel and farmer-beneficiaries on SWIS monitoring procedures, data management, maintenance practices, and water resource management. Capacity-building initiatives will ensure consistent application of monitoring guidelines and strengthen technical and community competencies.

8. It is further recommended that DENR-PENRO Albay adopt the proposed SWIS Monitoring Dashboard as an innovative monitoring tool to support the implementation, evaluation, and management of Small Water Impounding System projects. The proposed dashboard system will serve as a centralized platform for recording, storing, and analyzing monitoring data, including maintenance schedules, inspection results, water distribution status, and performance indicators. Through the use of a dashboard-

based monitoring system, technical personnel can easily track the condition of each SWIS site, identify operational gaps, and generate timely reports for decision-making. The dashboard will also improve coordination among technical personnel and stakeholders by providing organized and accessible information, thereby enhancing transparency, efficiency, and accountability in SWIS monitoring. The adoption of this proposed system is expected to strengthen the overall monitoring framework of DENR-PENRO Albay and support the long-term sustainability of Small Water Impounding System projects

Proposed Monitoring System for DENR-PENRO Albay's Small Water Impounding System (SWIS)

Based on the findings and conclusions of this study, a Small Water Impounding System (SWIS) Monitoring Dashboard is proposed as a monitoring framework developed to address identified gaps in monitoring practices, maintenance planning, water distribution management, and data utilization within DENR-PENRO Albay's SWIS implementation. As an output of the study, the dashboard is intended to strengthen monitoring and management processes by serving as a centralized monitoring and decision-support system that consolidates operational, environmental, and performance-related information into a unified platform. Through the integration of standardized indicators, data visualization tools, and participatory monitoring mechanisms, the dashboard aims to enhance evidence-based decision-making, improve transparency, and promote sustainable system operations.

The benefits of the proposed dashboard include faster access to monitoring information, improved coordination between technical personnel and farmer-beneficiaries, and clearer visualization of system performance indicators that support timely decision-making and preventive maintenance planning. By consolidating maintenance records, infrastructure condition status, rainfall data, water levels, and community participation metrics into one interface, the dashboard promotes consistency in reporting and helps reduce fragmented data management, which was identified as a performance gap in the study. It also encourages participatory monitoring by providing information that can be shared with stakeholders, fostering trust and collaboration while supporting the broader environmental goals of irrigation, reforestation, and climate resilience. However, the dashboard also has limitations. Its effectiveness depends heavily on regular data entry, the technical capability of users, and the availability of updated equipment and internet access; without these, the system may display incomplete or outdated information. Initial implementation may require training, budget allocation, and adjustment periods, and there is a risk that staff may rely too heavily on digital indicators without sufficient field validation, which could weaken contextual interpretation of on-site conditions.

In using the dashboard, technical personnel begin by entering or updating monitoring data gathered during site inspections, including infrastructure condition assessments, maintenance activities, water levels, and incidents observed in the field. The system then organizes these inputs into visual status cards, tables, and charts that allow users to quickly identify operational concerns such as sedimentation levels, overdue maintenance tasks, or irregular water distribution trends. The dashboard's maintenance and incidents module supports scheduling and documentation of repairs, while the resource utilization section enables monitoring of water allocation, budget use, and farmer-beneficiaries participation to evaluate operational efficiency. Users can interpret the displayed indicators to guide planning decisions, prioritize maintenance interventions, and communicate findings to stakeholders, ensuring that monitoring becomes continuous and responsive rather than periodic and reactive. Overall, the proposed dashboard functions as both a management tool and a monitoring framework that bridges the gap between policy guidelines and field-level implementation, reinforcing the study's objective of enhancing monitoring effectiveness and ensuring the long-term sustainability of SWIS operations in Albay.

**Small Water Impounding System (SWIS) Monitoring System
 SWIS USER MANUAL**

PENRO ALBAY		
No.	Section	Details
1	Introduction	The Small Water Impounding System (SWIS) Monitoring System is a dashboard-based application used to monitor SWIS projects in Albay. It tracks infrastructure condition, water levels, resources, maintenance, and incidents.
2	System Login / Access	Steps: 1. Open the system 2. Log in using Admin account 3. Dashboard will appear Navigation Menu: - Dashboard - Maintenance and Incidents
3	Dashboard Module	Displays overall SWIS status
3.1	Infrastructure Status	Components: - Dam - Spillway - Outlet Gate - Canal Lining - Sedimentation Color Indicators: - Red: Unknown - Blue: Percentage - Green: Active
3.2	Resource Utilization	Displays: - Water/Ha - Budget Used - Farmer Participation - Trainings Purpose: Track resource usage
3.3	Charts Overview	Charts: - Water Distribution - Water Level - Rainfall - Crop Yield Purpose: Visualize performance
3.4	Latest Water Level	Shows current water level in meters Example: 0 = no data Purpose: Monitor reservoir
4	Maintenance and Incidents	Access via left menu Tracks maintenance and issues
4.1	Maintenance Status	Components: Same as dashboard

		<p>Color Indicators:</p> <ul style="list-style-type: none"> - Red: No record - Blue: Percentage Updated when data is entered <p>Purpose:</p> <p>Track condition</p>
4.2	Maintenance Tasks	<p>Columns:</p> <ul style="list-style-type: none"> - Type - Description - Status - Scheduled - Completed <p>Steps:</p> <ol style="list-style-type: none"> 1. Click "Add Task" 2. Enter details 3. Save
4.3	Incidents	<p>Columns:</p> <ul style="list-style-type: none"> - Type - Description - Reported On - Status <p>Steps:</p> <ol style="list-style-type: none"> 1. Click "Add Incident" 2. Enter details 3. Save
5	Admin Panel	<p>Admin can:</p> <ul style="list-style-type: none"> - View dashboard - Add tasks - Add incidents - Monitor system Only authorized users can edit
6	Color Legend	<ul style="list-style-type: none"> - Red: No data - Green: Active - Blue: Value - Gray: No entries
7	Purpose of System	<ul style="list-style-type: none"> - Monitor SWIS - Track maintenance - Record incidents - Evaluate status - Support DENR guidelines
8	Recommended Use	<p>Update system after:</p> <ul style="list-style-type: none"> - Maintenance - Inspection - Rainfall - Irrigation - Training - Incidents

SWIS
Penro Albay Small Water Impounding System (SWIS) - Maintenance and Incidents

Dashboard
Maintenance and Incidents

System Maintenance

Dam
Unknown

Spillway
Unknown

Outlet Gate
Unknown

Canal Lining
Unknown

Sedimentation
0%

Maintenance Tasks

[Add Task](#)

Show 10 entries Search:

Type	Description	Status	Scheduled	Completed	Actions
No data available in table					

Showing 0 to 0 of 0 entries Previous Next

Recent Incidents

[Add Incident](#)

Show 10 entries Search:

Type	Description	Reported On	Status	Actions
No data available in table				

Showing 0 to 0 of 0 entries Previous Next

Admin
© 2026 Penro Albay Small Water Impounding System (SWIS) Monitoring System by Nikko Ologuer

SWIS
Penro Albay Small Water Impounding System (SWIS) Monitoring System

Dashboard
Maintenance and Incidents

Infrastructure Status

Dam
Unknown

Spillway
Unknown

Outlet Gate
Unknown

Canal Lining
Unknown

Sedimentation
0%

Resource Utilization

Water/Ha
0

Budget Used
0/0

Farmer Participation
0%

Trainings
0

Charts Overview

Latest Water Level
0 m

Daily Rainfall (mm)

1.0
0.9
0.8
0.7
0.6
0.5
0.4
0.3
0.2
0.1
0

Crop Yield per Date

1.0
0.9
0.8
0.7
0.6
0.5
0.4
0.3
0.2
0.1
0

Water Distribution Overview

Water Level (m)	Reservoir Capacity (%)
1.0	0.5
0.8	0.4
0.6	0.3
0.4	0.2
0.2	0.1
0	0
-0.2	0
-0.4	0
-0.6	0
-0.8	0
-1.0	0

Admin
© 2026 Penro Albay Small Water Impounding System (SWIS) Monitoring System by Nikko Ologuer

485

References

- Adam, M. (2025). Digital monitoring systems in public sector project management. *Journal of Project Management*, 12(2), 45–58.
- Armstrong, M. (2009). *Armstrong's handbook of performance management* (4th ed.). Kogan Page.
- Asian Development Bank. (2016). *Irrigation and water resource management guidelines*.
- Bareng, J. (2015). Performance evaluation of irrigation systems in the Cagayan River Basin. *Philippine Journal of Agricultural Engineering*, 7(1), 22–31.
- Briones, R. (2017). *Public resource management in Philippine irrigation projects*. Philippine Institute for Development Studies.
- Bruns, B., & Meinzen-Dick, R. (2018). *Water rights reform: Lessons for institutional design*. International Food Policy Research Institute.
- Bureau of Soils and Water Management. (2017). *Small Water Impounding Project (SWIP) operations manual*. Department of Agriculture.
- David, W. (2011). Institutional issues in irrigation management in the Philippines. *UPLB Journal of Development Studies*, 6(1), 15–28.
- Department of Agriculture – Bureau of Soils and Water Management. (2018). *Guidelines on small water impounding projects*.
- Department of Environment and Natural Resources. (2016). *Monitoring and evaluation guidelines for environmental projects*. DENR Central Office.
- Department of Environment and Natural Resources. (2019). *Guidelines on the implementation of Small Water Impounding Systems*. DENR Forest Management Bureau.
- Department of Environment and Natural Resources – Forest Management Bureau. (2019). *Operational guidelines for watershed and water impounding projects*.
- Department of Environment and Natural Resources – Forest Management Bureau. (2020). *National Greening Program monitoring manual*.
- Few, S. (2013). *Information dashboard design: Displaying data for at-a-glance monitoring* (2nd ed.). Analytics Press.
- Food and Agriculture Organization. (2017). *Irrigation and water management: Training manual*.
- Garcia, R., & Garcia, L. (2019). Performance of small water impounding systems in Luzon. *Philippine Agricultural Engineering Journal*, 11(2), 60–72.
- Harvey, P., & Reed, R. (2007). *Community-managed water supplies in developing countries*. ITDG Publishing.
- Intergovernmental Panel on Climate Change. (2021). *Climate change 2021: Impacts, adaptation, and vulnerability*. Cambridge University Press.
- Kusek, J., & Rist, R. (2004). *Ten steps to a results-based monitoring and evaluation system*. World Bank.
- Meinzen-Dick, R., & Zwarteveen, M. (2001). Gender dimensions of water control. *Agriculture and Human Values*, 18(1), 11–25.
- Mtebe, J., & Raisamo, R. (2020). A web-based monitoring and evaluation system for development projects. *International Journal of Information Systems*, 15(3), 101–112.
- National Irrigation Administration. (2018). *Operation and maintenance manual for irrigation systems*.
- Naval, R. (2016). Sustainability of small water impounding projects in Quirino Province. *Journal of Agricultural Development*, 5(2), 33–41.
- Panella, T. (2016). Water governance and irrigation management. *Water Policy Journal*, 8(3), 55–70.
- Power, D. (2002). *Decision support systems: Concepts and resources for managers*. Greenwood Publishing.
- Pretty, J. (2011). *Participatory learning for sustainable agriculture*. World Bank.
- Reyes, A. (2020). Monitoring and evaluation of government infrastructure projects in the Philippines. *Philippine Public Administration Review*, 14(1), 75–89.
- Rola, A. (2019). Institutional coordination in irrigation management in the Philippines. *Asian Journal of Agriculture and Development*, 16(1), 45–58.
- United Nations Development Programme. (2016). *Capacity development for sustainable water management*.
- World Bank. (2020). *Water resource management and irrigation performance report*.